



Assembly Instructions

Asher 3 Seat Sofa

(Product Codes: 69010018)













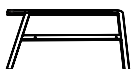

PLEASE RETAIN THIS DOCUMENT ALONG WITH YOUR
PROOF OF PURCHASE FOR FUTURE

Congratulations on your recent purchase of your beautiful Hartman furniture. We hope it brings you bountiful special moments with friends and family for many years to come. Please follow these simple steps to build your furniture. We also have a very useful video available online to assist with the assembly, please visit www.hartmanuk.com.

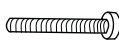
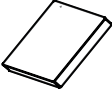
TOP TIPS

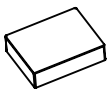
- Please read these instructions carefully before assembly, for further assistance please view our assembly video online for an easy step by step demonstration
- Aluminum is a soft metal and over tightening may strip the thread or break the part, please loosely assembly your furniture before tightening to secure.
- Please **do not** use power tools, please use the allen key provided in the bolt pack
- Please allow 5 minutes for assembly
- This furniture can be assembled with **2** persons; however, you may need someone to assist you when turning the furniture over into position.

PARTS LIST

Components					Fixings				
Parts List	Parts Picture	Description	Qty	Part no	Parts List	Parts Picture	Description	Qty	Part no
A		Seat Frame	1	69010018A	H		Washer (M6*φ16)	10	1061162
B		Armrest1	1	69010018B	I		Bolt (M6X35)	8	1111162
C		Armrest2	1	69010018C	J		Plastic bolt cap (M6)	12	1061163
D		Back Rest	1	69010018D	K		Allen (M6)	1	1010162
E		Center leg	1	69010018E	L		Bolt (M6X55)	2	1641162
F		Back cushion	3	5AHBC001MG	M		Washer (M6*φ12)	2	1241162
G		Seat cushion	3	5AHSC001MG	N		Bolt (M6X20)	2	1091162
					O		Plastic footpad	4	2PIF001
					P		Adjustable footpad	1	2PIF004

STEP 1 & 2: ARMREST ASSEMBLY

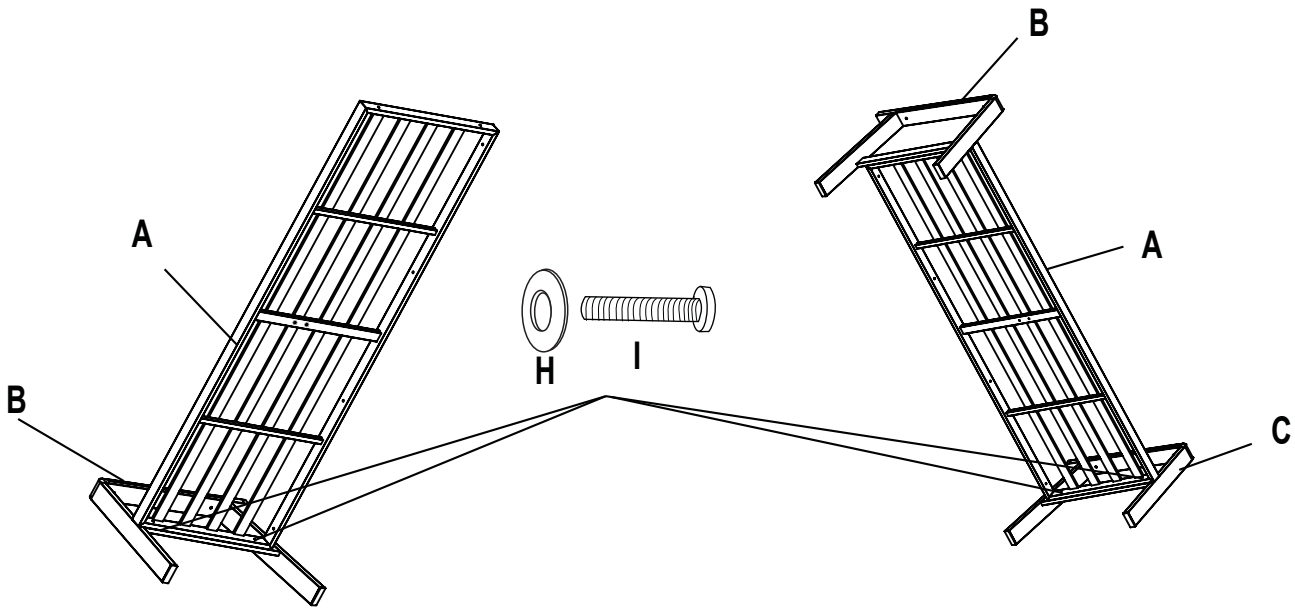

STEP 1: Attach Armrest 1 (B) to the Seat Frame (A) using the M6x35 Bolt (I) and Washer (H)

STEP 2: Repeat step 1 with Armrest 2 (C)

STEP 3 & 4: BACKREST AND LEG ASSEMBLY

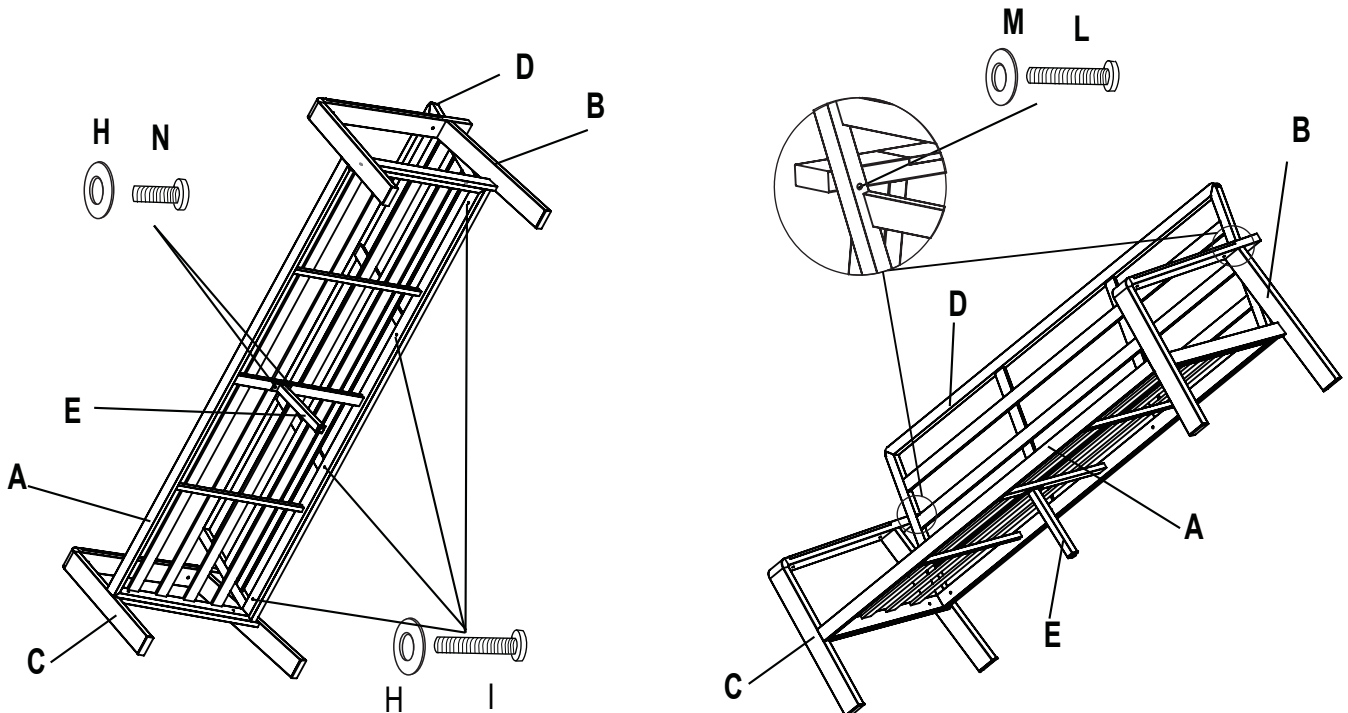

STEP 3: Attach Back Rest (D) to the Seat Frame (A) using the M6x35 Bolt (I) and Washer (H).

Attach Center leg(E) to Seat Frame (A) using the M6x20 Bolt (N) and Washer (H)

STEP 4: Attach Back Rest (D) to Armrest 1 (B) & Armrest 2 (C) using the M6x55 Bolt (L) and Washer (M),

STEP 5: TIGHTENING AND FINISHING

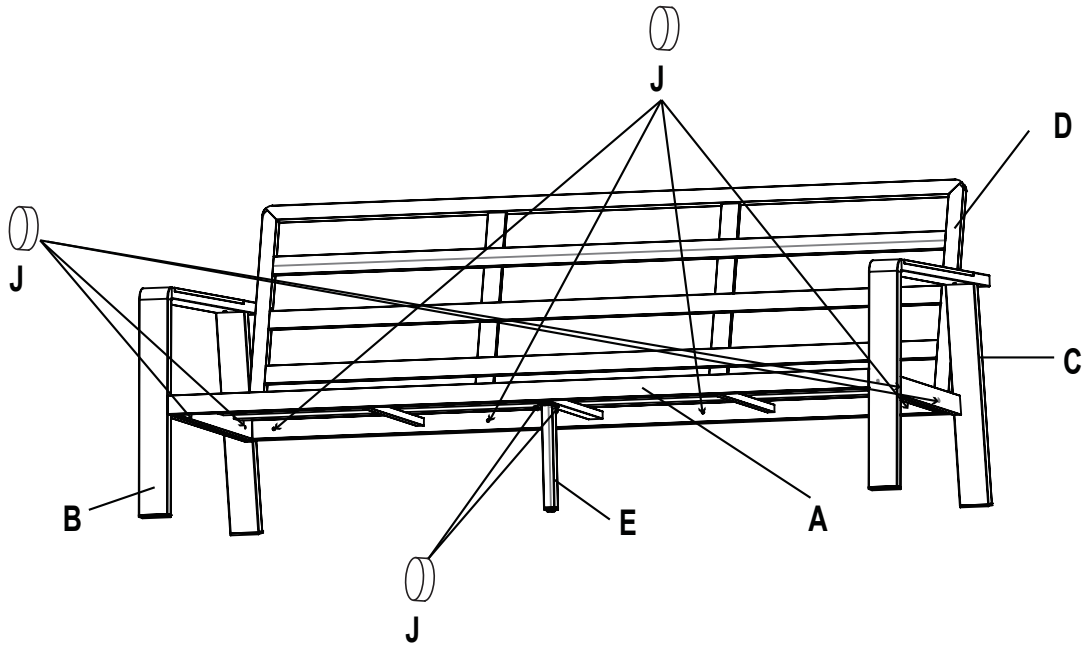

STEP 5: Tighten all the bolts on the sofa and cover with the Plastic bolt cap (J). Turn the sofa over and place the Seat cushion (G) and the Back cushion (F) onto the sofa