



# Assembly Instructions

## Asher Rectangular Adjustable Table

(Product Codes: 69015018&69016018)











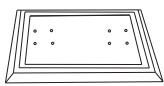

PLEASE RETAIN THIS DOCUMENT ALONG WITH YOUR  
PROOF OF PURCHASE FOR FUTURE

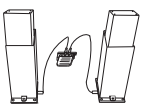
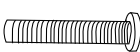
Congratulations on your recent purchase of your beautiful Hartman furniture. We hope it brings you bountiful special moments with friends and family for many years to come. Please follow these simple steps to build your furniture. We also have a very useful video available online to assist with the assembly, please visit [www.hartmanuk.com](http://www.hartmanuk.com).

### TOP TIPS

- Please read these instructions carefully before assembly, for further assistance please view our assembly video online for an easy step by step demonstration
- Aluminum is a soft metal and over tightening may strip the thread or break the part, please loosely assembly your furniture before tightening to secure.
- Please **do not** use power tools, please use the allen key provided in the bolt pack
- Please allow 5 minutes for assembly
- This furniture can be assembled with **2** persons; however, you may need someone to assist you when turning the furniture over into position.

## PARTS LIST

Components					Fixings				
Parts List	Parts Picture	Description	Qty	Part no	Parts List	Parts Picture	Description	Qty	Part no
A		Base	1	69015018A	D		Bolt (M6X25)	8	1017162
B		Table top	1	69015018B	E		Bolt (M6X35)	2	1111162
C		Gas pump	1	69016018C	F		Bolt (M8X50)	8	1012163
					G		Washer (M6)	10	1061162
					H		Washer (M8)	8	1062162
					I		Plastic bolt cap (M6)	10	1061163
					J		Plastic bolt cap (M8)	8	1061164
					K		Allen (M6)	1	1010162
					L		Allen (M8)	1	1051162
					M		Padjustable footpad	4	2SIF001

## STEP 1 & 2: GAS PUMP ASSEMBLY

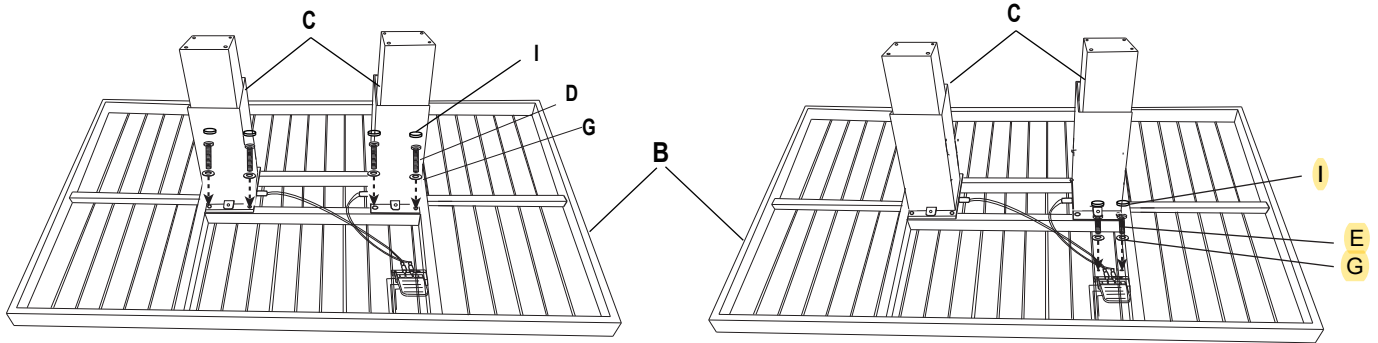

**STEP 1:** Attach Gas pump (C) to the Table top (B), using the M6x25 Bolt (D) and Washer (G). Tighten all the bolts with Allen (K), and cover with the Plastic bolt cap (I).

**STEP 2:** Attach the handle to the Table top (B), using the M6x35 Bolt (E) and Washer (G). Tighten all the bolts with Allen (K), and cover with the Plastic bolt cap (I).

## STEP 3 : BASE ASSEMBLY

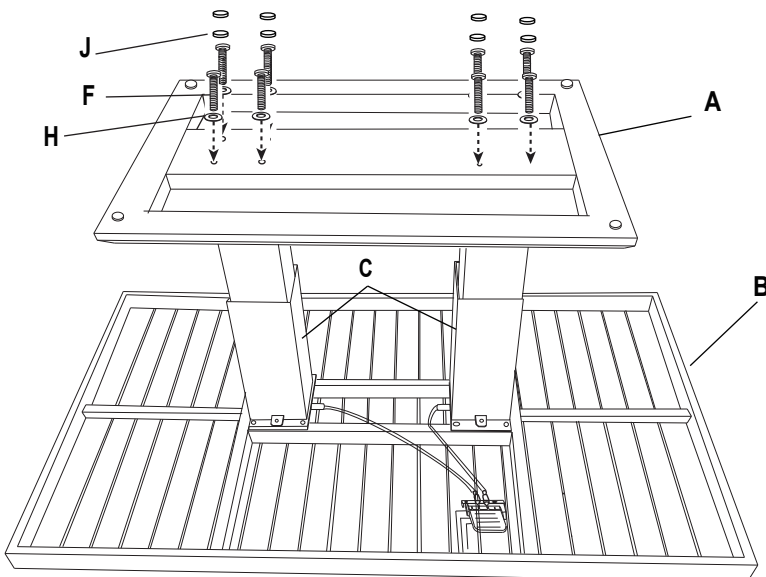

**STEP 3:** Attach Base (A) to the the Gas pump (C), using the M8x50 Bolt (F) and Washer (H). Tighten all the bolts with Allen (L), and cover with the Plastic bolt cap (J).

## STEP 4&5: COMPLETE AND TRY LIFT FUNCTION

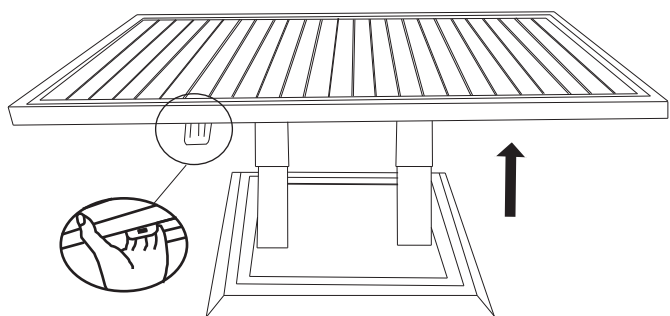

**STEP 4:** Squeeze the handle to raise the table top

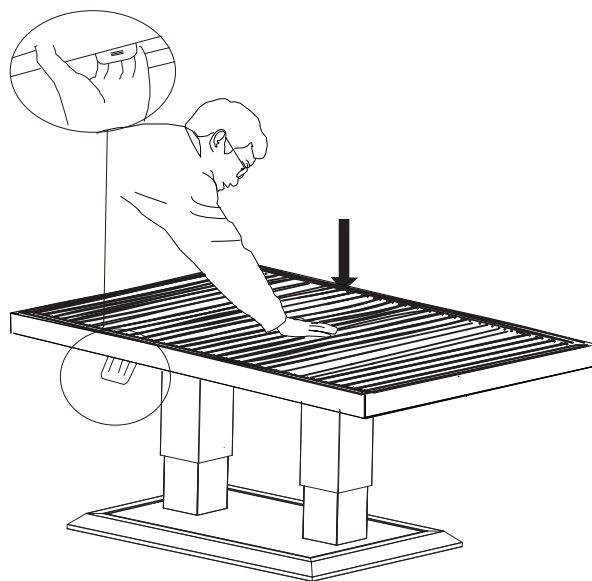

**STEP 5:** Press down in the center of Table top while squeezing the handle to lower the table top