



# Assembly Instructions

## Aspen Square Corner Seating Unit & 2 x Stools

(Product Codes: 60106049)

PLEASE RETAIN THIS DOCUMENT ALONG WITH YOUR  
PROOF OF PURCHASE FOR FUTURE

Congratulations on your recent purchase of your beautiful Hartman furniture. We hope it brings you bountiful special moments with friends and family for many years to come. Please follow these simple steps to build your furniture. We also have a very useful video available online to assist with the assembly, please visit [www.hartmanuk.com](http://www.hartmanuk.com).

### TOP TIPS

- Please read these instructions carefully before assembly, for further assistance please view our assembly video online for an easy step by step demonstration
- Aluminum is a soft metal and over tightening may strip the thread or break the part, please loosely assembly your furniture before tightening to secure.
- Please **do not** use power tools, please use the allen key provided in the bolt pack
- Please allow 5 minutes for assembly
- This furniture can be assembled with **2** person; however, you may need someone to assist you when turning the furniture over into position.



## STEP1&2: LEG ASSEMBLE

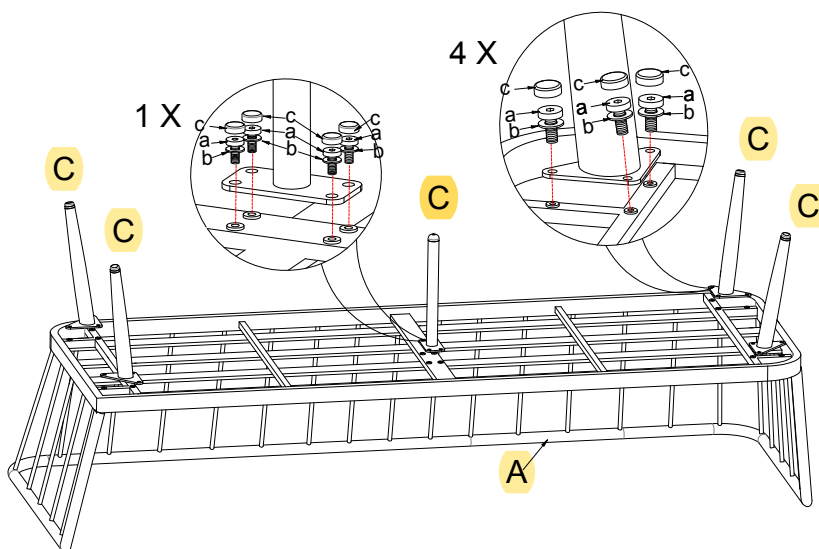

**STEP1:** Attach Legs (C) to the Seat Frame (A) using M6x15 Bolt (I) and Washer (J). Tighten all the bolts and finish with the Plastic bolt cap (K)

**STEP2:** Attach Center support leg (D) to the Seat Frame (A) using M6x15 Bolt (I) and Washer (J). Tighten all the bolts and finish with the Plastic bolt cap (K)

## STEP3: LEG ASSEMBLE

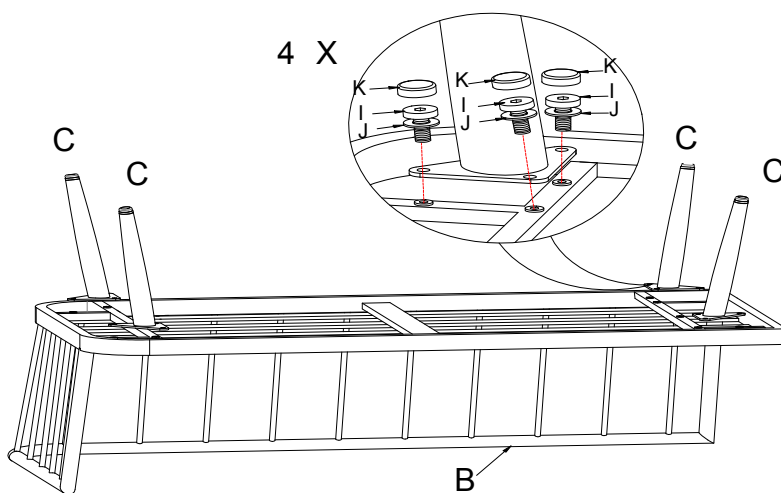





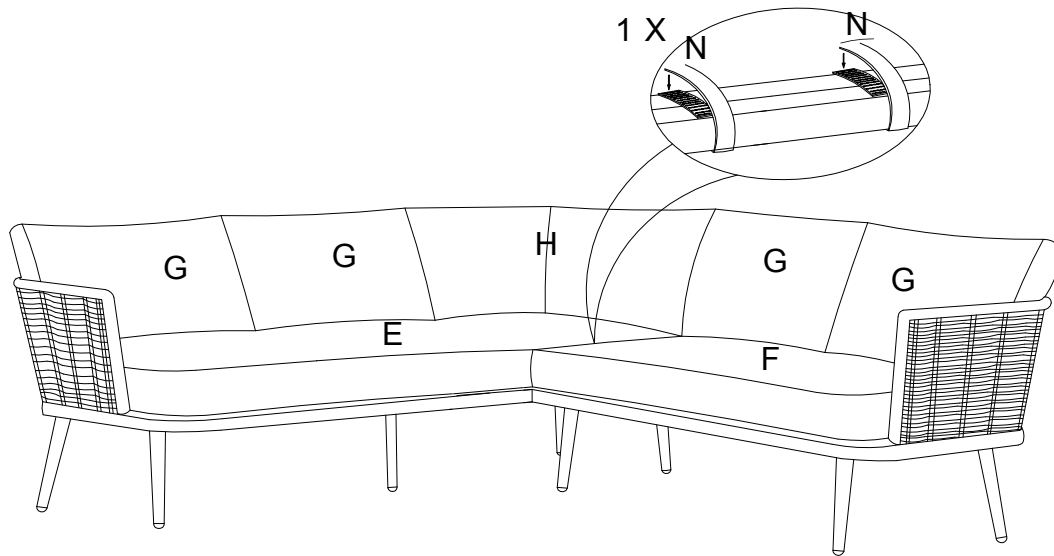

**STEP3:** Attach Legs (C) to the Seat Frame (B) using M6x15 Bolt (I) and Washer (J). Tighten all the bolts and finish with the Plastic bolt cap (K)

**STEP4: COMPLETE**



**STEP4:** Turn the sofa over and place the cushion(E) (F) (G) (H) onto the sofa

## PARTS LIST---Stool

Component's					Fixings				
Parts List	Parts Picture	Description	Qty	Part no	Parts List	Parts Picture	Description	Qty	Part no
O		Stool Seat Frame	1	60106049O	I		Bolt (M6x15)	12	1011162
C		leg (32cm L)	4	60106049C	J		Washer (M6xø14)	12	1241163
P		Stool seat cushion	1	5APST001MA	K		Plastic bolt cap (M6)	12	1061163
					L		Allen (M6)	1	1010162
					M		Adjustable plastic footpad 25mm	4	2PNS004

## STEP1: LEG ASSEMBLY

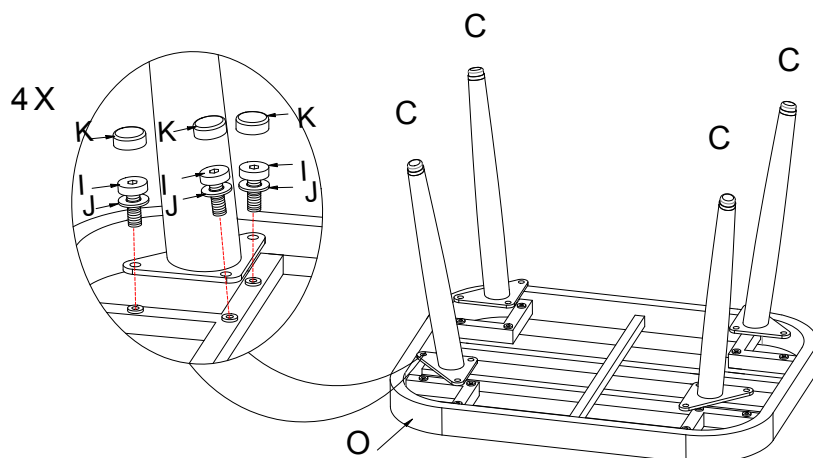

**STEP1:** Attach Legs (C) to the Stools Seat Frame (O) using M6x15 Bolt (I) and Washer (J). Tighten all the bolts and finish with the Plastic bolt cap (K)

## STEP2: COMPLETE

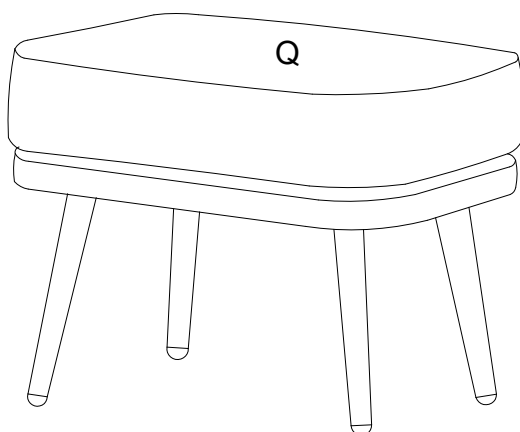

**STEP2:** Turn the Stools over and place the cushion (Q) onto the Stool

