

# 26" WALK-BEHIND SWEEPER

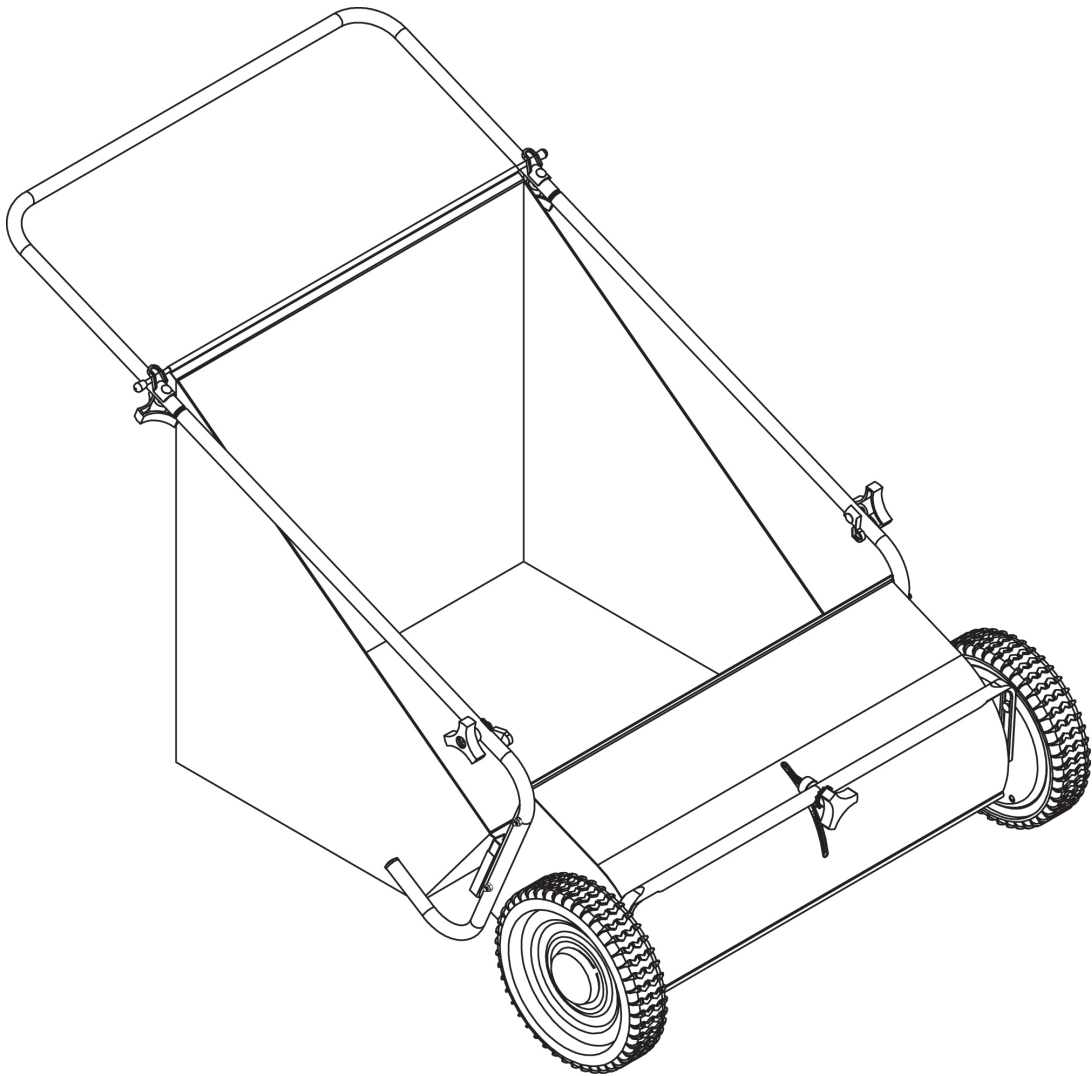

## Instruction & Assembly

SAVE THESE INSTRUCTIONS FOR FUTURE REFERENCE

# Table of Contents

General Warnings and Rules .....	3
Hazard Signal Word Definitions.....	4
Controls and Features Identification.....	5
Component & Hardware.....	6
Assembly Instructions .....	7, 8, 9
Operation Instructions .....	10, 11
Maintenance and Storage .....	11, 12, 13, 14, 15
Specification.....	15
Parts Drawing & Parts List .....	16,17, 18



## GENERAL WARNINGS



**READ and UNDERSTAND this manual completely before using the Push Sweeper.**

Operator must read and understand all safety and warning information, operating instructions, maintenance and storage instructions before operating this equipment. Failure to properly operate and maintain the push sweeper could result in serious injury to the operator or bystanders.

### **Operation Warnings**

- Do not at any time carry passengers, sit or stand on the sweeper.
- Do not allow children to play on, stand upon or climb in the sweeper.
- Always inspect the sweeper before using to assure it is in good working condition.
- Replace or repair damaged or worn parts immediately.
- Always check and tighten hardware and assembled parts before operation.
- Avoid large holes and ditches when using the sweeper.
- Be careful when operating on steep grades (hill) the sweeper may tip over.
- Do not push close to creeks, ditches and public highways.
- Always use caution when unloading sweeper.
- Never tow the sweeper with a motorized vehicle.

### **Crush and Cut Hazards**

- Always keep hands and feet clear from moving parts while operating the equipment.
- Always clear and keep work area clean when operating.
- Always wear safety gear, eye protection, gloves and work boots when operating the sweeper.



### **WARNING**

The warnings, cautions, and instructions outlined in this instruction manual cannot cover all possible conditions or situations that may occur. It must be understood by the operator that common sense and caution are factors which cannot be built into this product and must be supplied by the operator.







### **PROP 65 WARNING**

This product contains chemicals known to the state of California to cause cancer, birth defects, or other reproductive harm.

### **Assembly Is Required**

This product requires assembly before use. See "Assembly" section for instructions. Because of the weight and/or size of the push sweeper, it is recommended that another adult be present to assist with the assembly. **INSPECT ALL COMPONENTS** closely upon receipt to make sure no components are missing or damaged.

# Hazard Signal Word Definitions

	<p>This is the safety alert symbol. It is used to alert you to potential personal injury hazards. Obey all safety messages that follow this symbol to avoid possible injury or death.</p>
	<p><b>DANGER</b> indicates an imminently hazardous situation which, if not avoided, will result in death or serious injury.</p>
	<p><b>WARNING</b> indicates a potentially hazardous situation which, if not avoided, could result in death or serious injury.</p>
	<p><b>CAUTION</b> indicates a potentially hazardous situation which, if not avoided, may result in minor or moderate injury.</p>
	<p><b>CAUTION</b> used without the safety alert symbol indicates a potentially hazardous situation which, if not avoided, may result in property damage.</p>

## ABOUT YOUR PUSH SWEEPER

This heavy duty push sweeper makes yard work a breeze. The steel and poly construction is durable, lightweight and is easy to push. The extra-large sweeping span makes the job easy and saves time when cleaning different types of debris from grass, twigs, paper, leaves and much more. The push sweeper features an easy one-handed turn function to adjust the brush height. It can be stored in a shed, garage or on the wall. The large 7 cubic-foot hopper makes loading and unloading fast and convenient.

Technical specifications on the push sweeper are provided in the “Specifications” section of this manual.

## Controls and Features Identification

Read this owner's manual before operating the equipment. Familiarize yourself with the location and function of the controls and features. Save this manual for future reference.

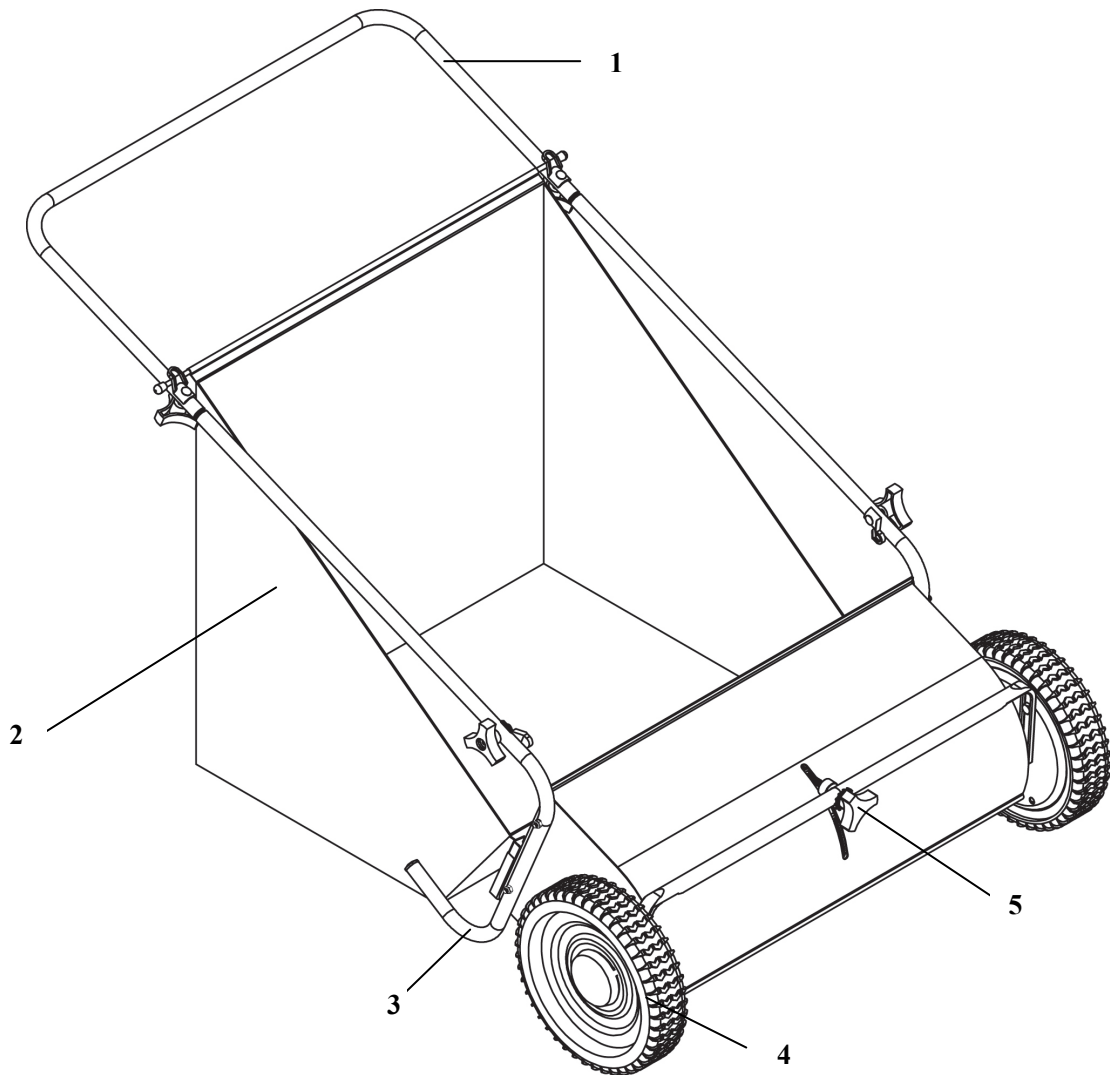

- 1) **Handle** – Pushes and moves the sweeper easily.
- 2) **Hopper Bag** – Do not exceed the rated load capacity 7 Cu. Ft.
- 3) **Support Leg** – Stabilizes load and sweeper.
- 4) **Tires / Wheel** – Heavy duty 10" tires.
- 5) **Hand Knob** – Adjust brush height.



## CAUTION

Read and follow all instructions for assembly and operation. Failure to properly assemble this equipment could result in serious injury to the user or bystanders, or cause equipment damage.

### PUSH SWEEPER COMPONENT PARTS AND ASSEMBLY

Take all parts out of the shipping crate and inspect components to ensure there are no missing pieces before starting to assemble the push sweeper follow steps 1 through 5.

#### TOOLS REQUIRED

- 10mm Wrenches

## Component Parts

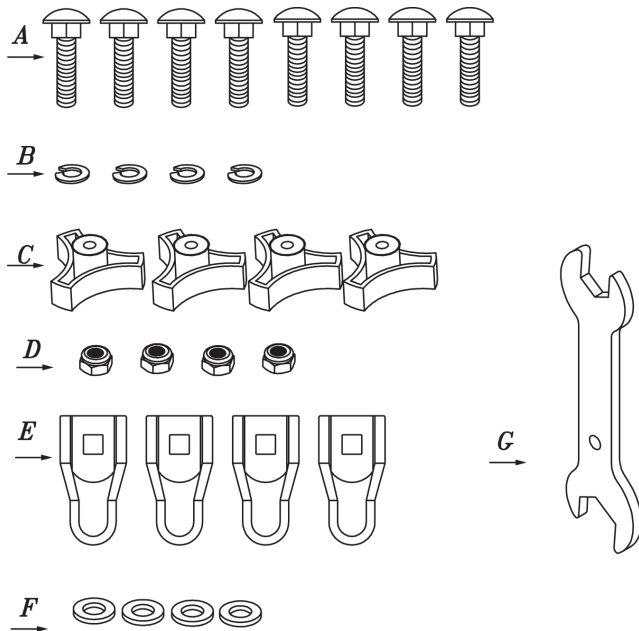

REF.	QTY.	DESCRIPTION
A	8	M6x30 Carriage Bolt
B	4	Ø6 Lock Washer
C	4	Handle Knob
D	4	M6 Nylon Lock Nut
E	4	Bag Rod Clips
F	4	Ø6 Flat Washer
G	1	Wrench

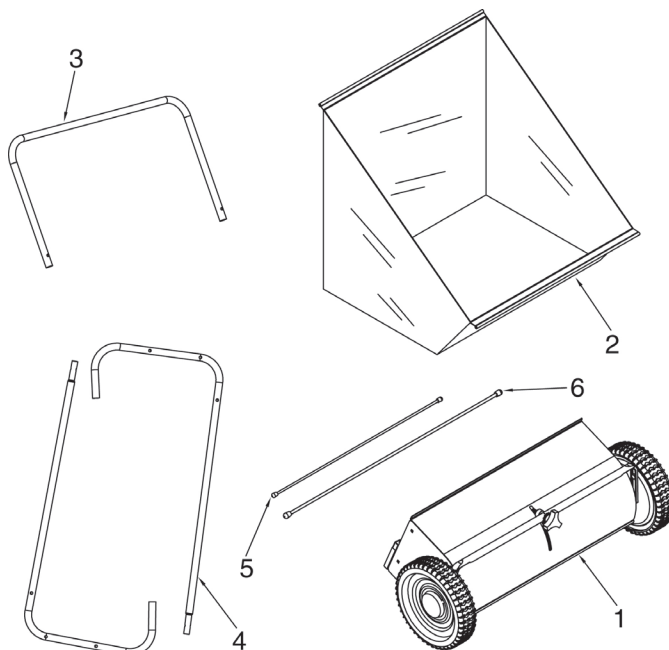

REF.	QTY.	DESCRIPTION
1	1	Sweeper Assembly
2	1	Hopper Bag
3	1	Handle Frame
4	2	Support Leg
5	1	Short Bag Rod
6	1	Long Bag Rod

# Assembly Instructions

## STEP 1: Install Support Legs to Sweeper Housing

1. Attach the supporting leg to the sweeper assembly and secure with M6 x 30 carriage bolt and M6 nylon lock nut (Fig. 1). Loosely tighten and repeat for the other side.

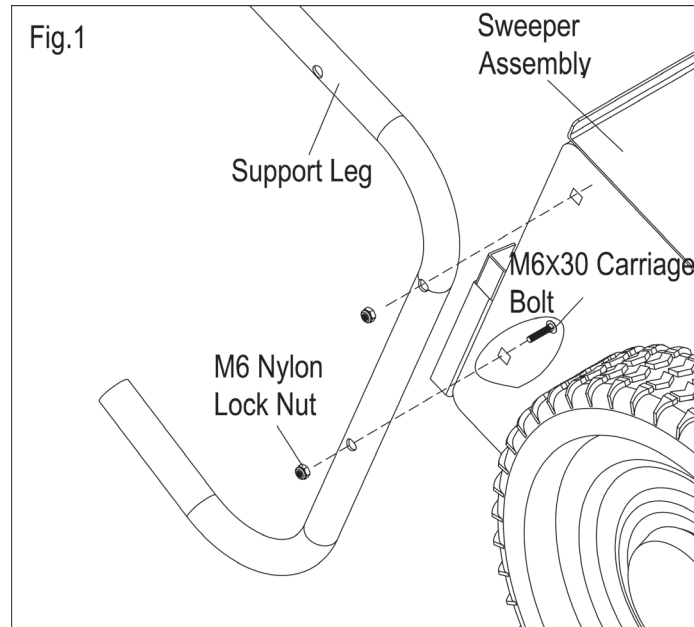

## STEP 2: Attach Push Handle to Support Legs

1. Insert the handle frame into the supporting legs (Fig. 2).
2. Secure handle frame to the supporting legs with the M6 x 30 carriage bolts, bag rod clips, flat washers, lock washers, and handle knobs (Fig. 3).
3. Tighten all hardware in both steps.

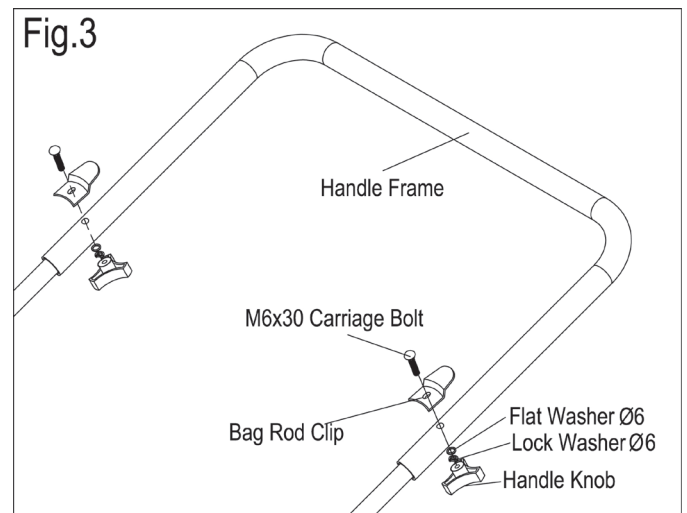
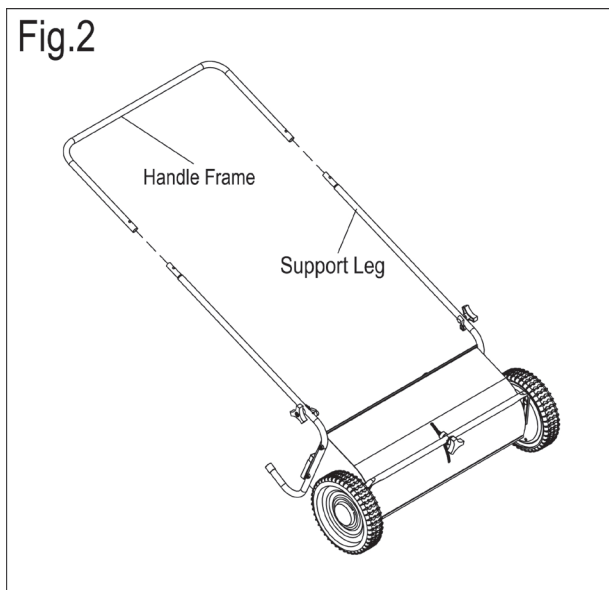

### STEP 3: Attach Bag Rod Clips

1. Put a bag rod clip on each side of the support legs and secure using a M6 x 30 carriage bolt, a flat washer, a lock washer, and a handle knob (Fig. 4).

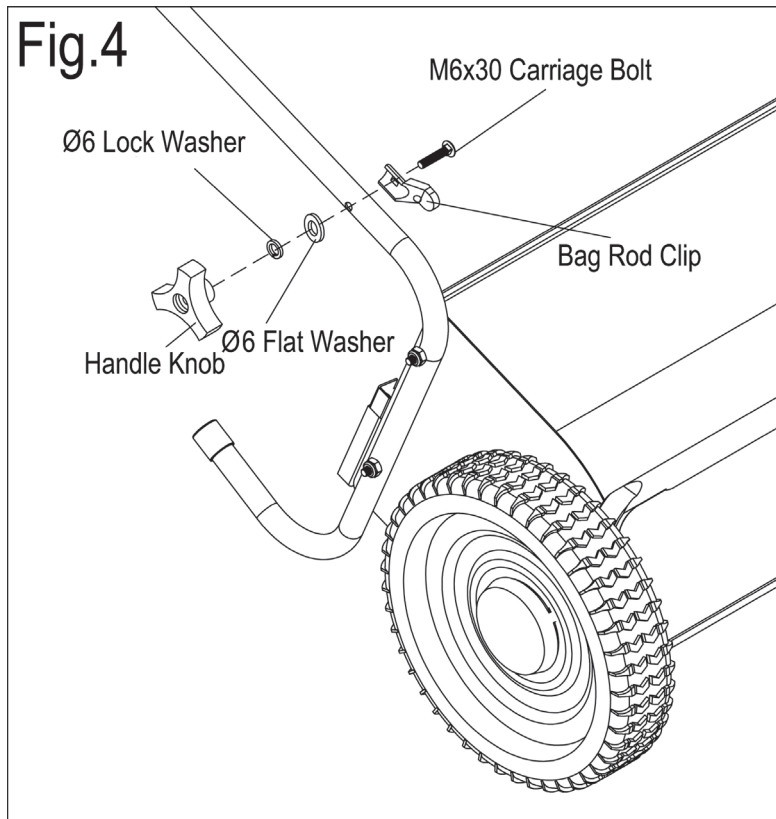

### STEP 4: Assemble Hopper Bag Hardware

1. Slide the long bag rod through the top opening in the hopper bag. Slide the short bag rod through the bottom of the hopper bag. (Fig. 5).

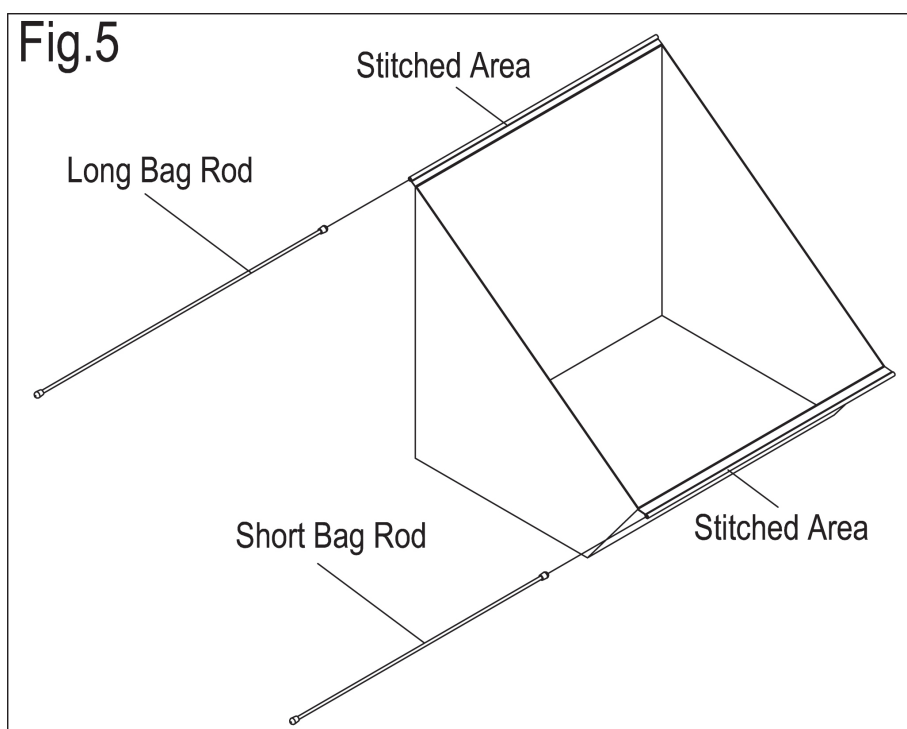



## STEP 5: Attach Hopper Bag to Sweeper

1. Place the hopper bag assembly inside the sweeper frame. Insert the long rod into the two rod clips at the top and the shorter rod into the clips at the bottom.
2. Hook the plastic straps on the bag flaps under the bag clips on the supporting legs (Fig. 6).
3. Make sure all hardware is installed correctly before operating the sweeper.

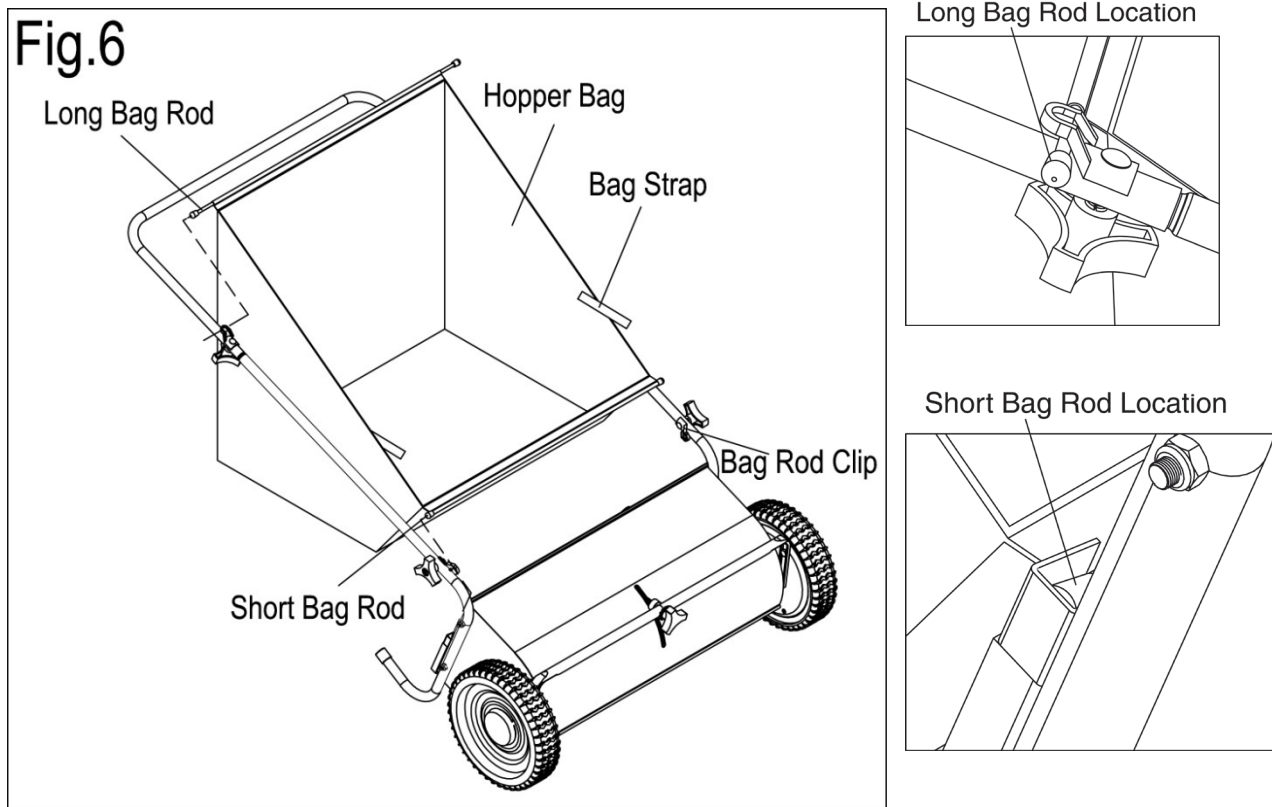

# Operation Instructions

## WARNING

Before using the push sweeper, make sure the sweeper is correctly assembled and all hardware is fully tightened.

## Brush Height Adjustment

1. Unlock the height adjustment lock by turning the locking knob counterclockwise (Fig. 7).

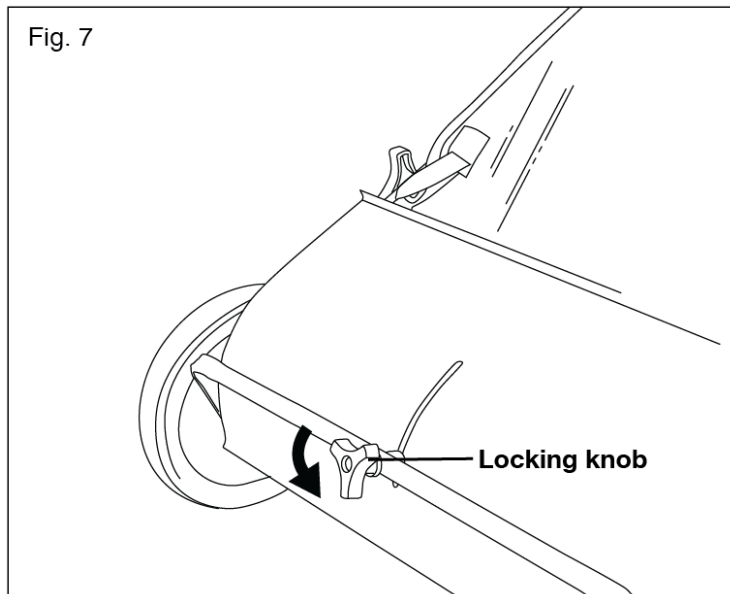

2. Use hand to hold the handle (see arrow) to adjust the brush height by lifting the handle up and down several times. Tighten the handle knob to the desired height.

**Note: You may need to use your hands to slide the height adjustment tube for placement.**

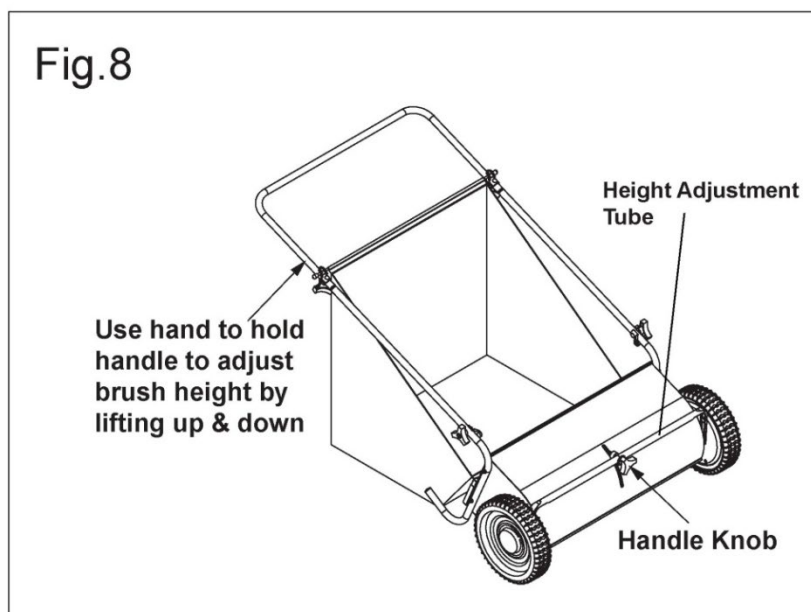

## Basic Sweeping Method

Push sweeper forward at normal walking speed; it does not operate when pulled backwards.

**NOTE:** For best results mow the grass to an even height before sweeping.

## Dumping Hopper Bag

1. To dump the hopper bag, tip the sweeper forward allowing the material to fall out.
2. You can also take the hopper bag off of the sweeper to dump.

**WARNING!** Always dump hopper bag after each use. Damp or wet grass and leaves will cause damage to hopper if stored for an extended period of time.

**WARNING!** DO NOT dump or unload the sweeper too close to fire as the brushes and the hopper bag can be destroyed by excessive heat of flame.

## Maintenance

### General

- After each use, dump and clean the hopper.
- Rinse/dry inside and outside of the sweeper after each use.
- Periodically check all nuts, bolts, and screws for proper tightness.
- Annually clean out and lightly lubricate parts.
- Use a glossy enamel spray paint to touch up scratched or worn painted metal surface.
- Never exceed the hopper load capacity rating of 52.3 gal (198 l) It will damage the hopper bag.

### Lubrication

The bearings in the sweeper have been pre-lubricated at the factory. However it's recommended that a few drops of light oil should be added to the brush shaft bearings twice a year. Also, the gear should be cleaned every two years. After cleaning apply an even coat of light grease.

1. Use a screw driver to pop off the hub cap (Fig. 9).

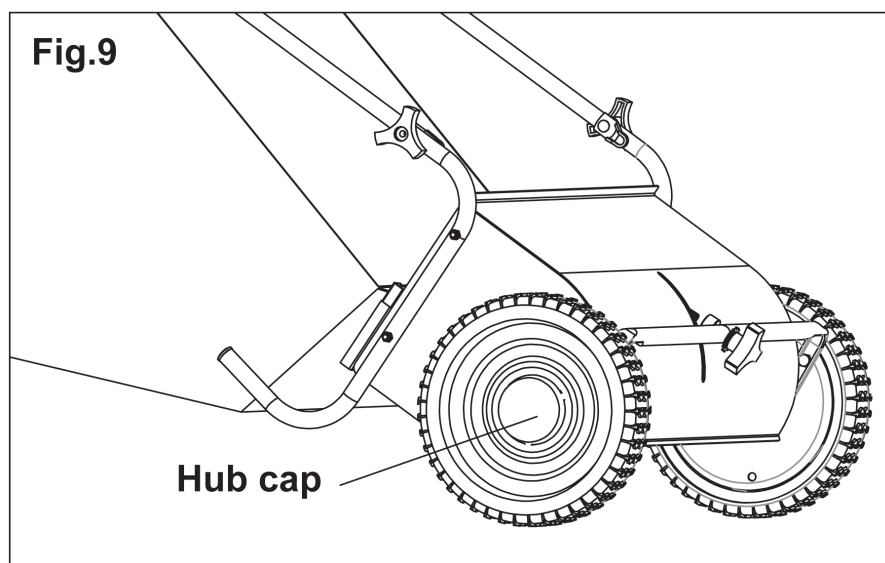

2. To remove the wheel, take out the circlip and the flat washer; you will see the gear and the shaft (Fig. 10).

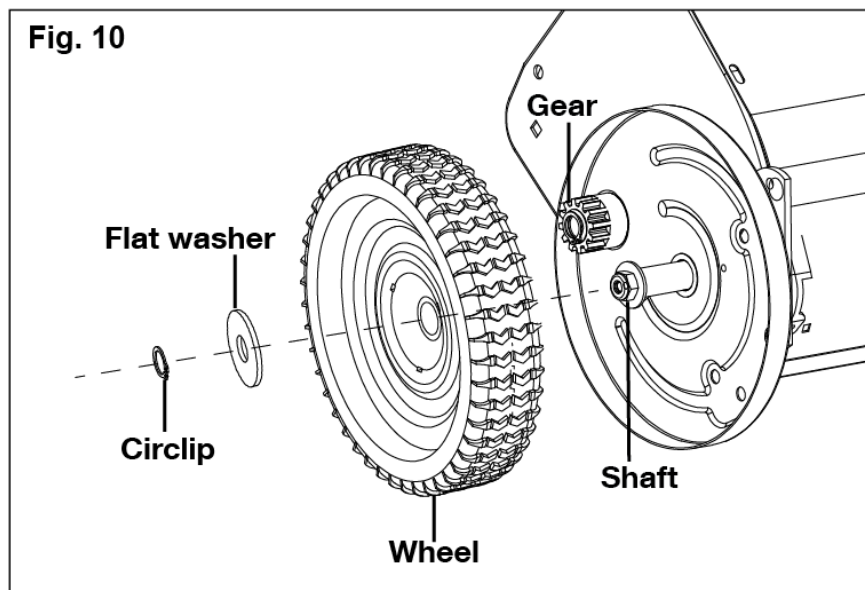

3. Remove the circlip on the gear, the gear can be taken off easily (Fig. 11).

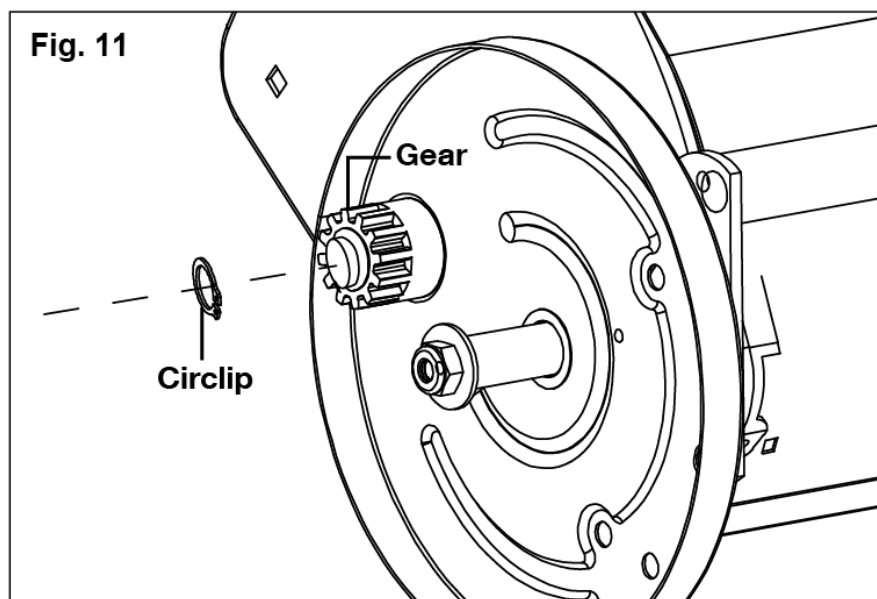

4. Clean the gear and lubricate the shaft as needed, then reassemble the wheel in a reverse sequence.

## Brush Replacement

1. Before replacing the brush, remove the hopper bag from the sweeper, and flip the sweeper over.
2. Remove all the nuts and bolts on the brush retainers used for securing the brushes (Fig. 12).

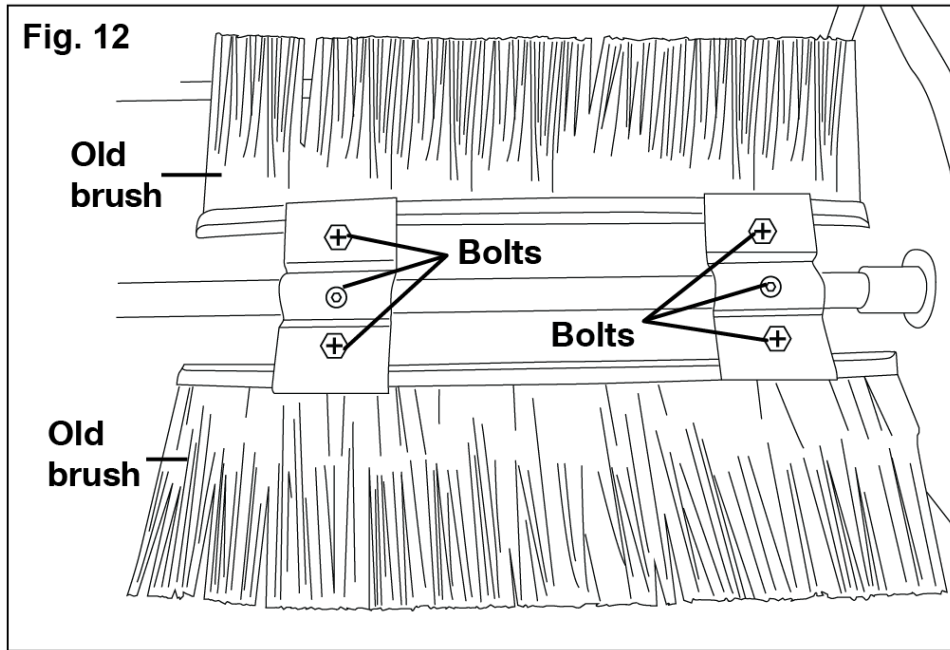

3. Remove the old brushes, the long brush retainer, and the short brush retainer from the sweeper (Fig. 13).

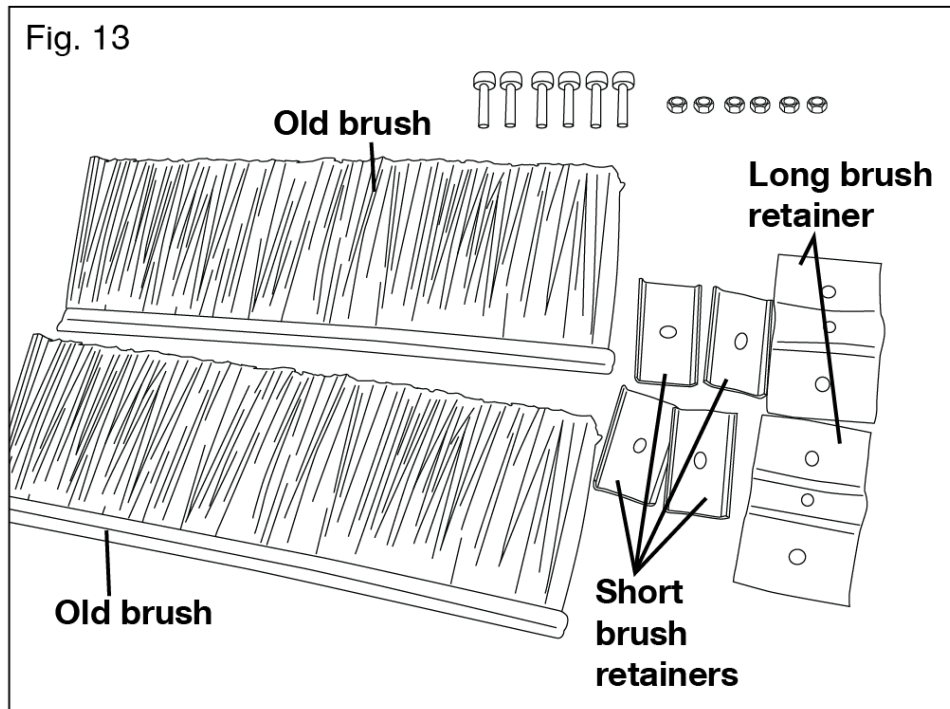

4. Insert new brushes between the long brush retainer and the short brush retainer; fix with M6 nuts and hex bolts (Fig. 14).

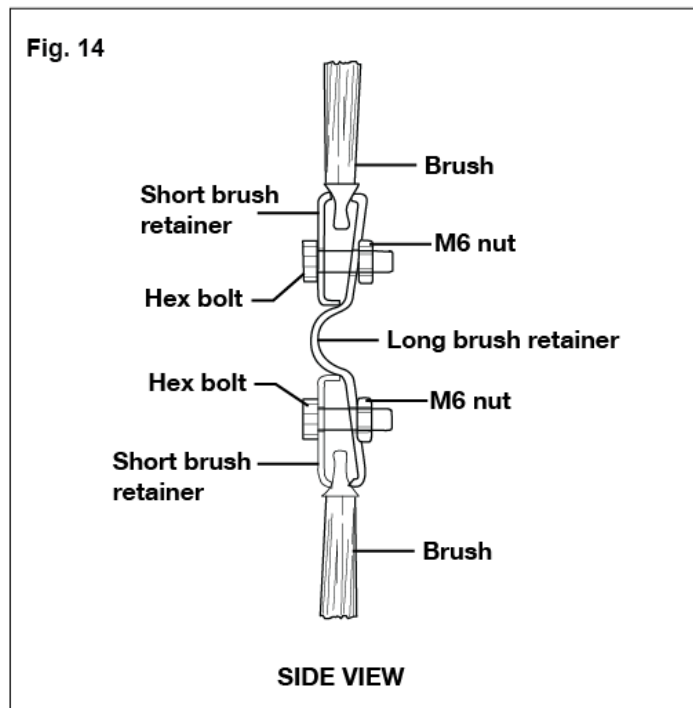

5. Fit the brush assembly onto the brush shaft; fix with a M5 nut and a M5 bolt (Fig. 15).

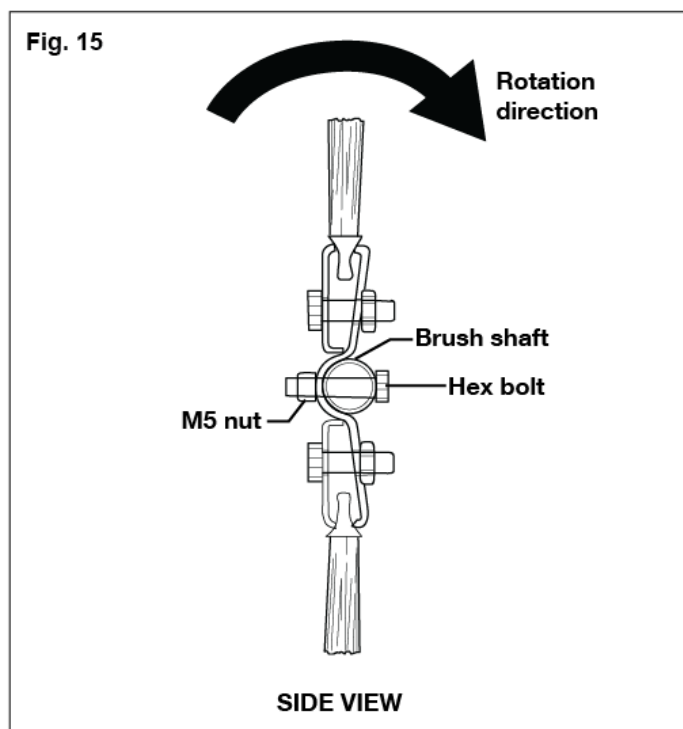

6. Repeat the steps to install the remaining brush.

**NOTE:** The two set of brushes should remain vertical to each other after assembly (Fig. 16).

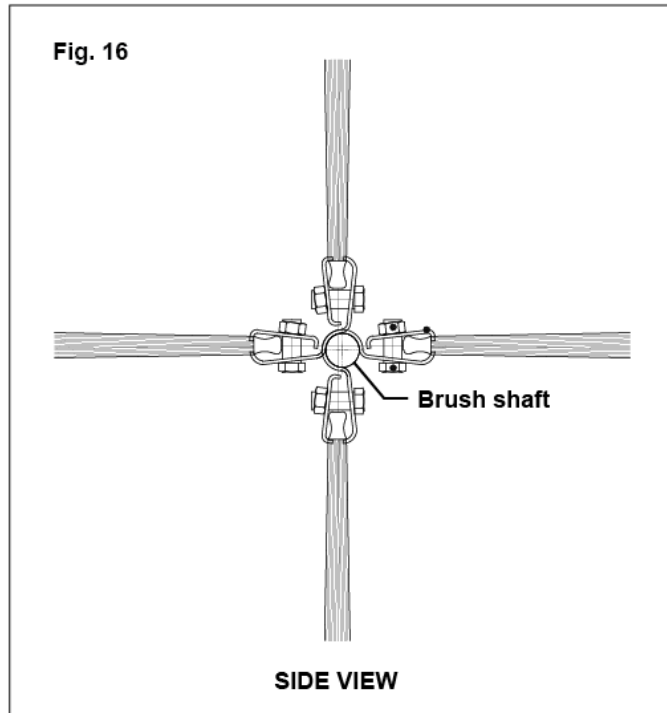

### Storage

1. Store indoors or in protected area during severe weather and winter months.
2. Never allow anything left in the hopper bag to remain for an extended period of time.
3. Before storing, make sure the sweeper is dry and clean.

## Specifications

Load Capacity .....	7 CU FT
Sweeper Type .....	Push
Hopper Material .....	Polypropylene
Hopper Dimensions .....	23.6" x 22" x 25.5" (9.4")
Overall Dimensions .....	48.9" x 32.52" x 30.35"
Wheel size .....	10"

# Parts Drawing & Parts List

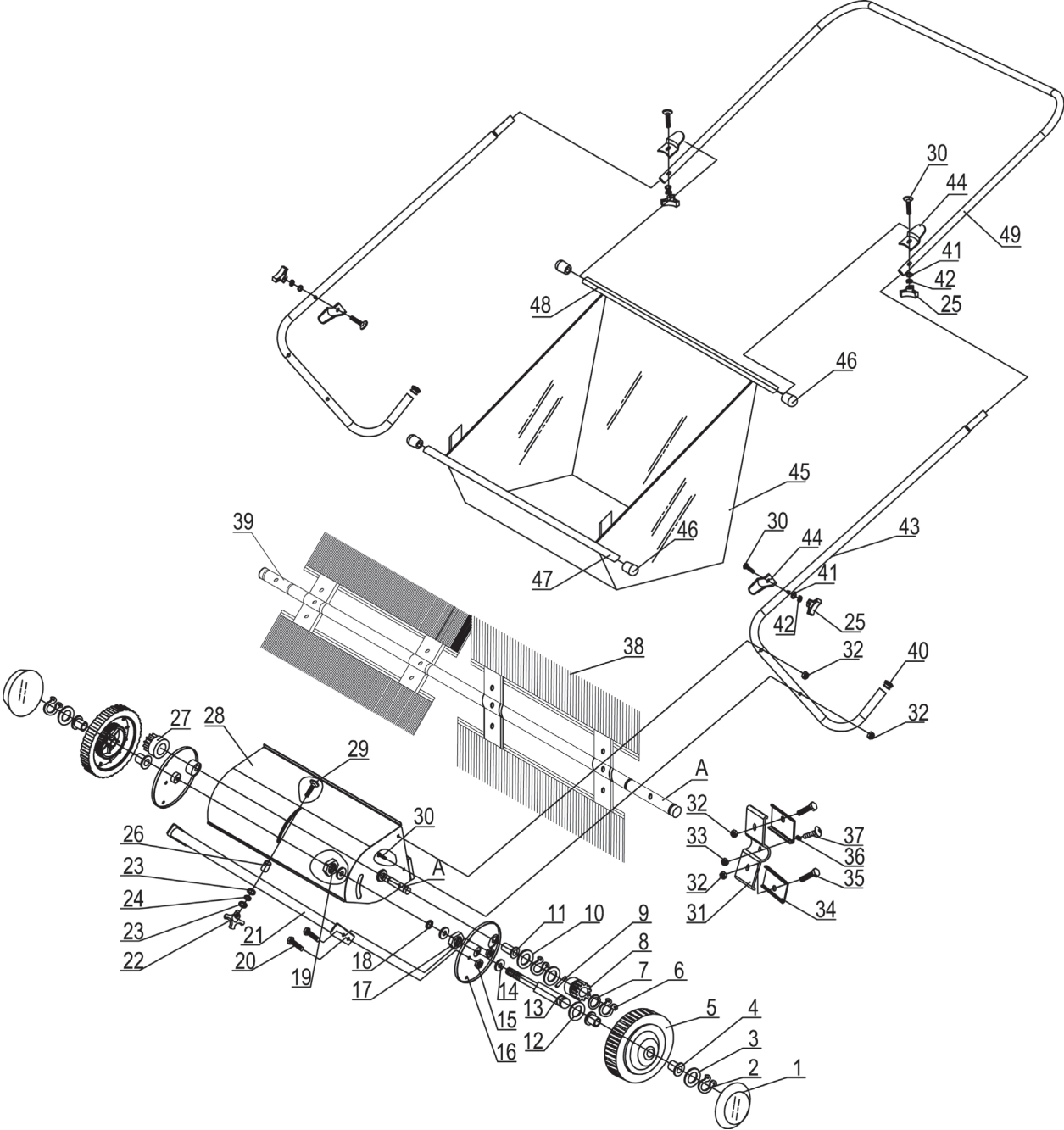



## Parts Drawing & Parts List

Ref#	Drawing No.	Description	Qty
1	N280-00032	Plastic Cover for wheel	2
2	9304-16000-FH	Back Ring Ø16	2
3	9307-16000-DX	Flat Washer Ø16	2
4	NS2600-00004	Bushing	4
5	N280-20000	Wheel	2
6	9304-15000-FH	Back Ring Ø15	4
7	N280-00037-FH	Washer for Adjustment B	2
8	N280-00030	Pinion Gear L.H.	1
9	9401-06020	Pin of Gear	2
10	N280-00029-FH	Washer for Adjustment A	4
11	NS2600-00008	Bearing for Brush	2
12	NS2600-00006	Washer for Adjustment F	2
13	NS2600-00009-DX	Wheel Axle	2
14	9302-10000-DX	Big Washer Ø10	6
15	9206-08000-DX	Nylon Lock Nut M8	4
16	NS2600-00005	Dust Cover Assembly	2
17	9201-10000-DX	Hex Nut M10	2
18	N280-00036-DX	Endplate Bushing	2
19	9206-10000-DX	Nylon Lock Nut M10	2
20	9101-08012-DX	Hex Bolt M8×12	4
21	NS2600-00001	Connect Tube	1
22	N280-70000	Knob	1
23	9302-08000-DX	Big Flat Washer Ø8	2
24	9310-08000-FH	Wave Washer	1
25	NS2600-00015	Handle Knob	4
26	NS2600-00014	Cushion Washer	1
27	N280-00012	Pinion Gear R.H.	1
28	NS2600-10000	Housing Assembly	1
29	9114-08055-DX	Carriage Bolt M8×55	1
30	9114-06030-DX	Carriage Bolt M6×30	8

## Parts Drawing & Parts List

31	N280-30001-DX	Brush Clamp	4
32	9206-06000-DX	Nylon Lock Nut M6	12
33	9206-05000-DX	Nylon Lock Nut M5	4
34	N280-30002-DX	Brush Retainer	8
35	9102-06020-DX	Hex Bolt M6×20	8
36	9316-05000-FH	Star Washer Ø5	4
37	9102-05025-DX	Hex Bolt M5x25	4
38	NS2600-21000	Brush	4
39	NS2600-00007-DX	Brush Axle	1
40	N990-00011	Plug	2
41	9301-06000-DX	Flat Washer Ø6	4
42	9306-06000-DX	Lock Washer Ø6	4
43	NS2600--00002	Support Leg	2
44	NS2600-00003	Bag Rod Clip	4
45	NS2600-30000	Hopper Bag	1
46	NS2600-00011	Plastic End Cover	2
47	NS2600-00012-DX	Short Bag Rod	1
48	NS2600-00013-DX	Long Bag Rod	1
49	NS2600-00010	Handle Frame	1