



Assembly Instructions

Alora 3 Seat Lounge Set

(Product Codes: 61333091, 61333099, 61121091,
61121099, 61129091, 61129099)

**PLEASE RETAIN THIS DOCUMENT ALONG WITH YOUR
PROOF OF PURCHASE FOR FUTURE REFERENCE**

Congratulations on your recent purchase of your beautiful Hartman furniture. We hope it brings you countless special moments with friends and family for many years to come.

Please follow these simple steps to build your furniture. We also have a very useful video available online to assist with the assembly, please visit www.hartmanuk.com

TOP TIPS

- Please read these instructions carefully before assembly, for further assistance please view our assembly video online for an easy step by step demonstration.
- Aluminium is a soft metal and over tightening may strip the thread or break the part, please loosely assembly your furniture before tightening to secure.
- Please **do not** use power tools, only use the tools provided in the bolt pack.
- Please allow 1 hour for assembly.
- This furniture can be assembled with **1** person; however, you may need someone to assist you when turning the furniture over into position.



Assembly Instructions

Alora 3 Seat Sofa (61333091/61333099)















**PLEASE RETAIN THIS DOCUMENT ALONG WITH YOUR PROOF
OF PURCHASE FOR FUTURE REFERENE**

Congratulations on your recent purchase of your beautiful Hartman furniture. We hope it brings you bountiful special moments with friends and family for many years to come. Please follow these simple steps to build your furniture. We also have a very useful video available online to assist with the assembly, please visit www.hartmanuk.com

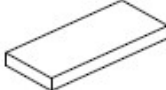
TOP TIPS

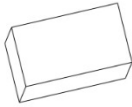
- Please read these instructions carefully before assembly. For further assistance please view our assembly video online for an easy step by step demonstration.
- Aluminium is a soft metal and over tightening may strip the thread or break the part, please loosely assemble your furniture before tightening to secure.
- Please do not use power tools, please only use the tools provided in the bolt pack.
- Please allow 1 hour for assembly.
- This furniture can be assembled by 2 people as you may need someone to assist you when turning the furniture over into position.

PARTS LIST

Components					Fixings				
Parts List	Parts Picture	Description	Qty	Part No.	Parts List	Parts Picture	Description	Qty	Part No.
A		Seat Frame	1	61333091A 61333099A	E		M6x15 Bolt	2	1011162
B		Back Frame	1	61333091B 61333099B	F		M6x30 Bolt	4	1101162
C		Armrest 1	1	61333091C 61333099C	G		M6x40 Bolt	3	1121162
D		Armrest 2	1	61333091D 61333099D	H		M6x16 Washer	9	1061162
E		Seat Cushion	1	61333091E 61333099E	I		M6 Allen Key	1	1010162
F		Back Cushion	2	61333091F 61333099F	J		Bolt Cap	9	1061163
					K		Footpad	4	1061178
					L		Adjustable Foot	4	1061179

STEP 1 & 2: ARMREST ASSEMBLY

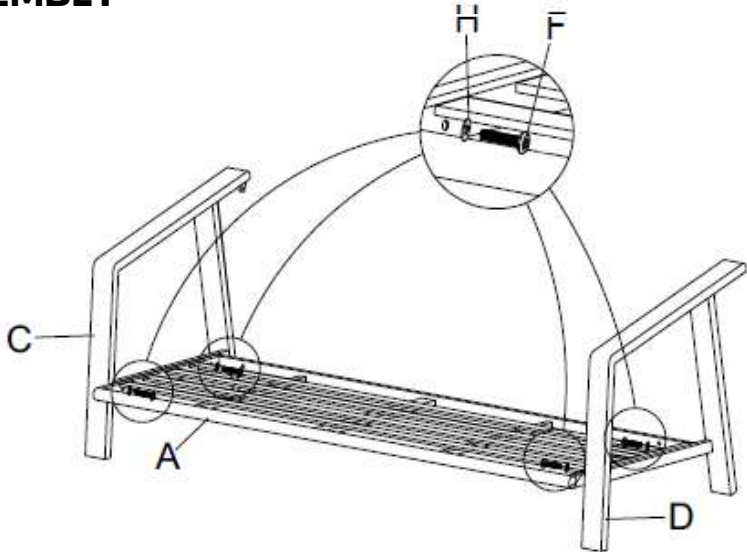

STEP 1: Attach armrest 1 (C) to the seat frame (A) using the bolt M6x30 (F) and Washer (H)
STEP 2: Repeat STEP1 to attach the armrest 2 (D) to the seat frame (A)

STEP 3 - 5: BACKREST & CENTER LEG ASSEMBLY

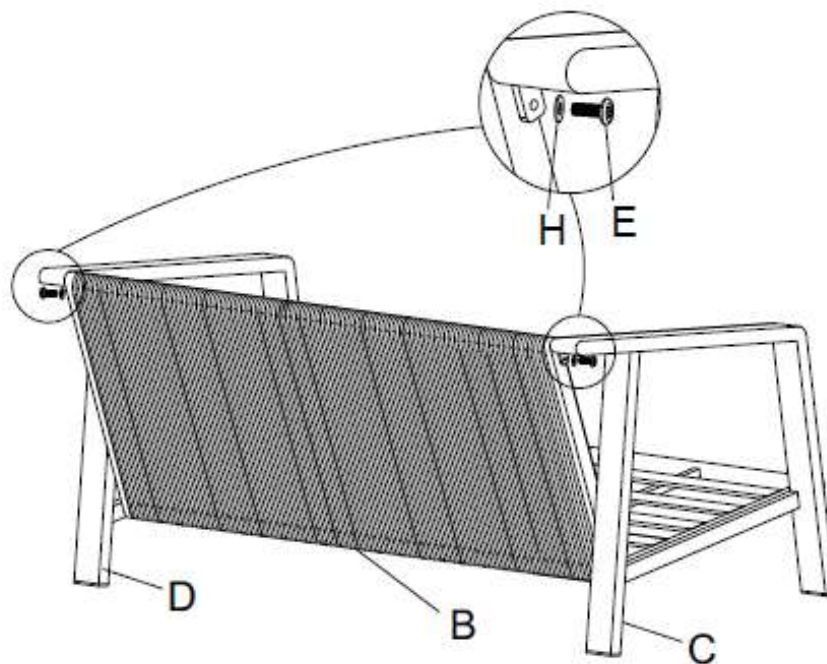

STEP 3: Attach backboard (B) to the armrest 1 (C) & armrest 2 (D), using the bolt M6x15 (E) and Washer (H)

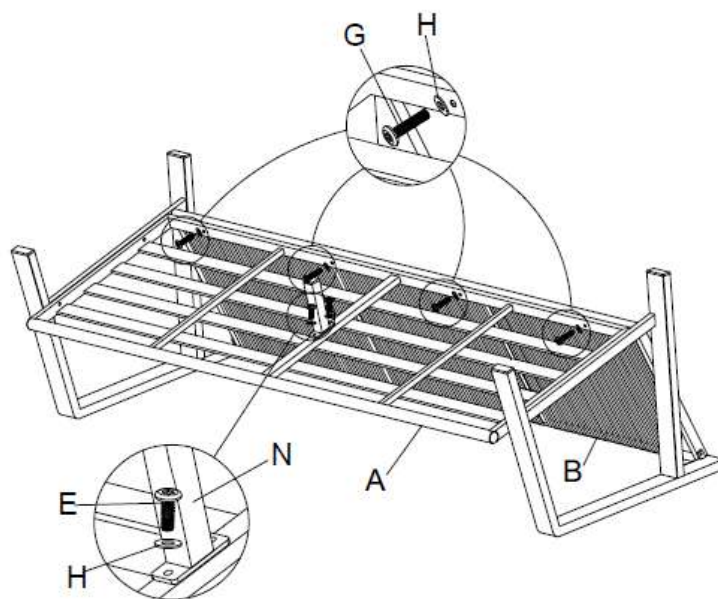

STEP 4: Attach Backboard (B) to the seat frame (A) using the bolt M6x40 (G) and Washer (H)

STEP 5: Attach center leg (N) to the seat frame (A) using the bolt M6x15 (E) and Washer (H)

STEP 5: TIGHTEN AND FINISHING

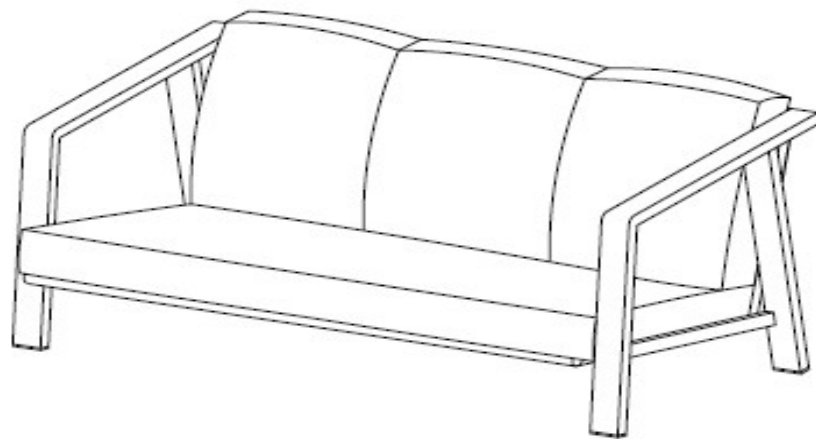
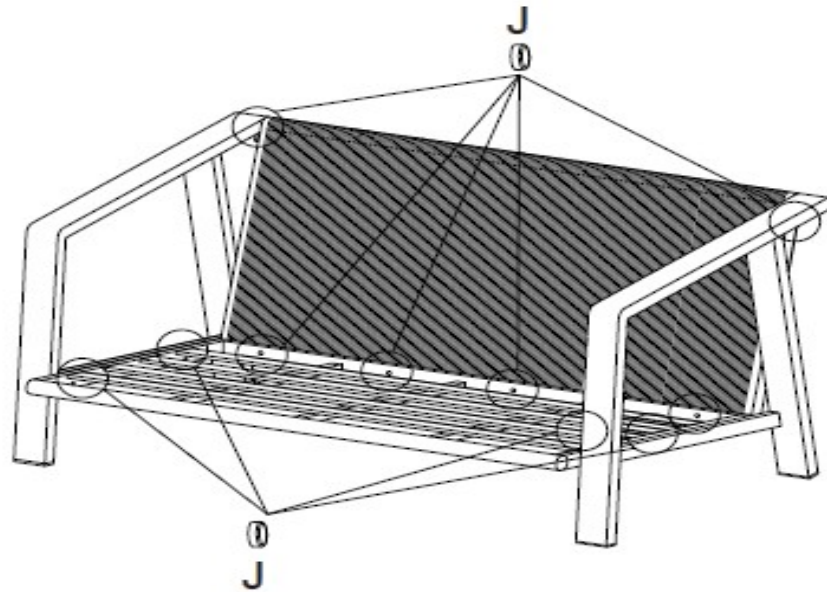

STEP 5: Tighten all the bolts on the chair and finish with the bolt cap (J).
Turn the chair over and place the seat cushion (L) and the back cushion (M) onto the chair



Assembly Instructions

Alora Lounge Chair (61121091/61121099)













**PLEASE RETAIN THIS DOCUMENT ALONG WITH YOUR PROOF
OF PURCHASE FOR FUTURE REFERENE**

Congratulations on your recent purchase of your beautiful Hartman furniture. We hope it brings you bountiful special moments with friends and family for many years to come. Please follow these simple steps to build your furniture. We also have a very useful video available online to assist with the assembly, please visit www.hartmanuk.com

TOP TIPS

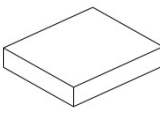
- Please read these instructions carefully before assembly. For further assistance please view our assembly video online for an easy step by step demonstration.
- Aluminium is a soft metal and over tightening may strip the thread or break the part, please loosely assemble your furniture before tightening to secure.
- Please **do not** use power tools, please only use the tools provided in the bolt pack.
- Please allow 1 hour for assembly.
- This furniture can be assembled by 1 person; however, you may need someone to assist you when turning the furniture over into position.

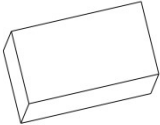
PARTS LIST

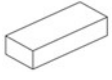
Components					Fixings				
Parts List	Parts Picture	Description	Qty	Part No.	Parts List	Parts Picture	Description	Qty	Part No.
A		Seat Frame	1	61121091A 61121099A	G		M6x15 Bolt	2	101162
B		Back Frame	1	61121091B 61121099B	H		M6x30 Bolt	4	1101162
C		Armrest 1	1	61121091C 61121099C	I		M6x40 Bolt	2	1121162
D		Arm Rest 2	1	61121091D 61121099D	J		M6x16 Washer	8	1061162
E		Seat Cushion	1	61121091E 61121099E	K		M6 Allen Key	1	1010162
F		Back Cushion	1	61121091F 61121099F	L		Bot Cap	8	1061163
					M		Footpad	4	1061178

STEP 1 & 2: ARMREST ASSEMBLY

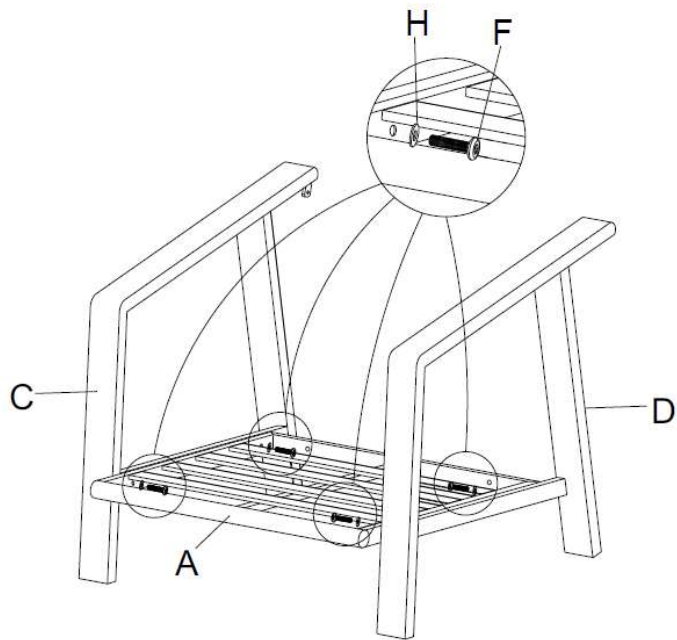

STEP 1: Attach armrest 1 (C) to the seat frame (A) using the bolt M6x30 (F) and Washer (H)
STEP 2: Repeat step 1 to attach the armrest 2 (D) to the seat frame (A)

STEP 3 & 4: BACKREST ASSEMBLY

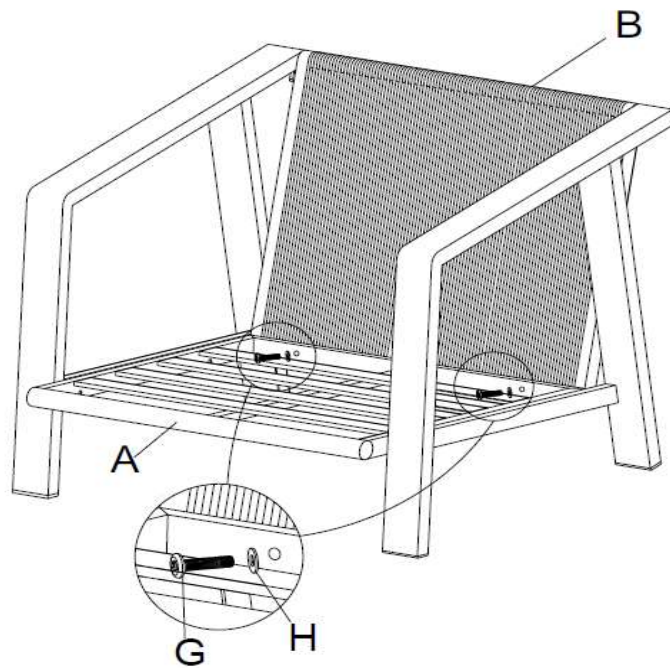
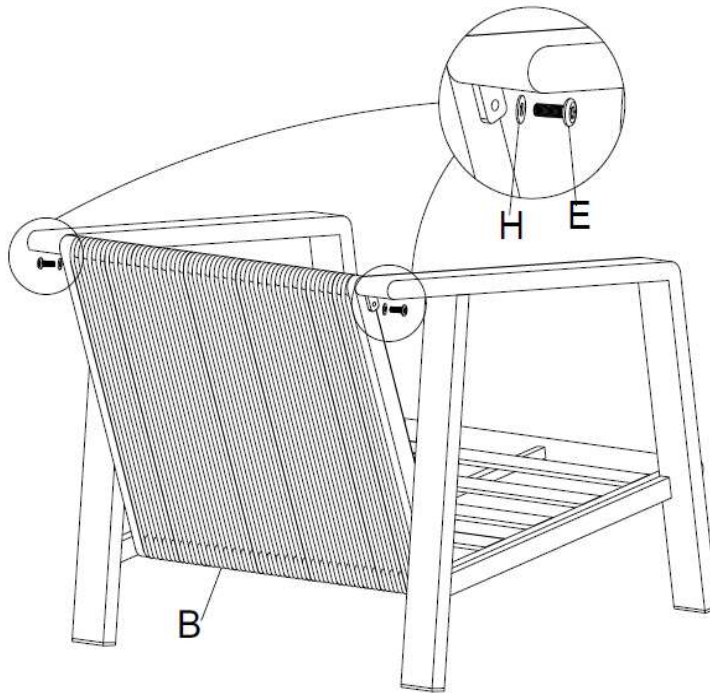

STEP 3: Attach back board (B) to the armrest 1 (C) & armrest 2 (D), using the bolt M6x15 (E) and Washer (H)

STEP 4: Attach Backboard (B) to the seat frame (A) using the bolt M6x40 (G) and Washer (H)

STEP 5: TIGHTEN AND FINISHING

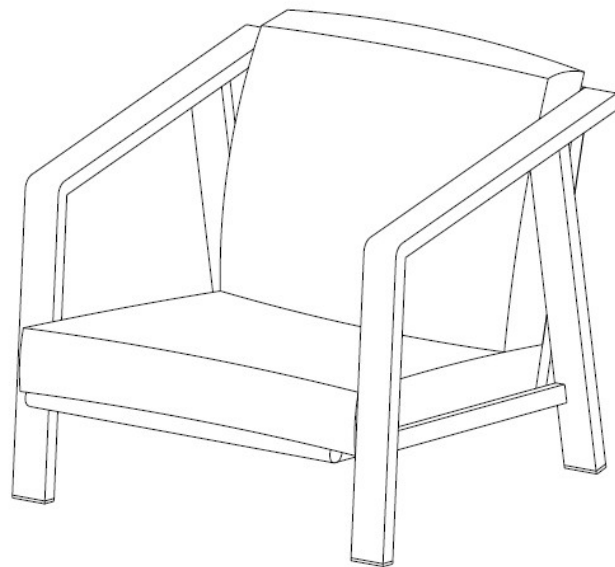
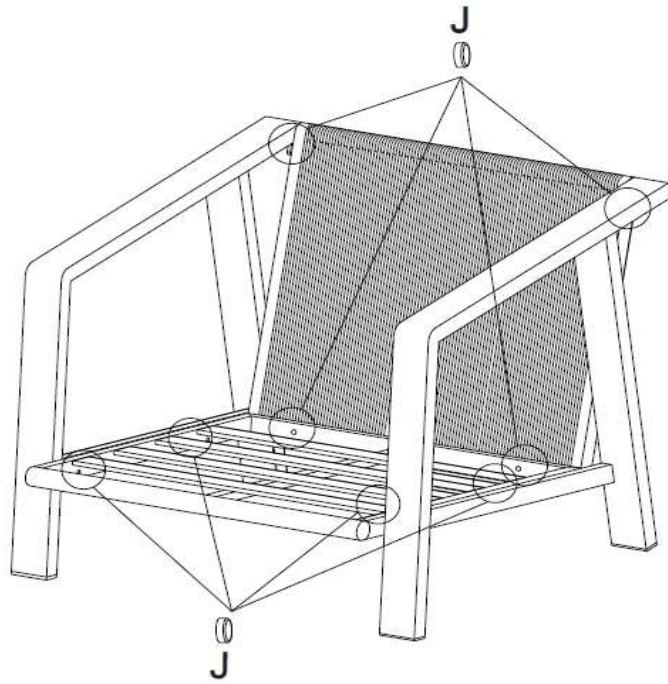

STEP 5: Tighten all the bolts on the chair and finish with the bolt cap (J).
Turn the chair over and place the seat cushion (L) and the back cushion (M) onto the chair.



Assembly Instructions

Alora 170 x 75cm Rectangular Coffee Table (61129091/61129099)









**PLEASE RETAIN THIS DOCUMENT ALONG WITH YOUR PROOF
OF PURCHASE FOR FUTURE REFERENE**

Congratulations on your recent purchase of your beautiful Hartman furniture. We hope it brings you bountiful special moments with friends and family for many years to come. Please follow these simple steps to build your furniture. We also have a very useful video available online to assist with the assembly, please visit www.hartmanuk.com

TOP TIPS

- Please read these instructions carefully before assembly. For further assistance please view our assembly video online for an easy step by step demonstration.
- Aluminium is a soft metal and over tightening may strip the thread or break the part, please loosely assemble your furniture before tightening to secure.
- Please **do not** use power tools, please only use the tools provided in the bolt pack.
- Please allow 1 hour for assembly.
- This furniture can be assembled by **2** people as you may need someone to assist you when turning the furniture over into position.

PARTS LIST

Components					Fixings				
Parts List	Parts Picture	Description	Qty	Part No.	Parts List	Parts Picture	Description	Qty	Part No.
A		Table Top	1	61129091A 61129099A	D		M6x15 Bolt	12	1011162
B		Leg 1	1	61129091B 61129099B	E		M6x16 Washer	12	1061162
C		Leg 2	2	61129091C 61129099C	F		M6 Allen Key	1	1010162
					G		Bolt Cap	12	1061163
					H		Adjustable Foot	4	1061179

STEP 1 : LEGS ASSEMBLY

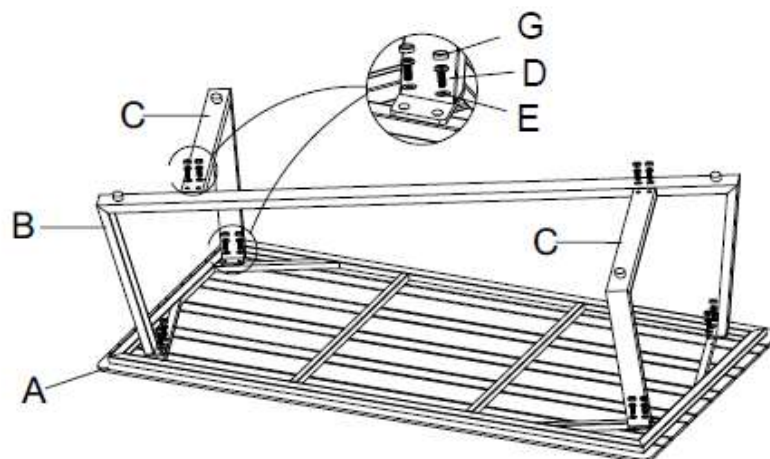

STEP 1: Attach leg2 (C) to the leg1 (B), using the bolt M6x15 (D) and Washer (E)
Then attach the leg to the table top (A), using the bolt M6x15 (D) and Washer (E).

STEP 2: FINISHING

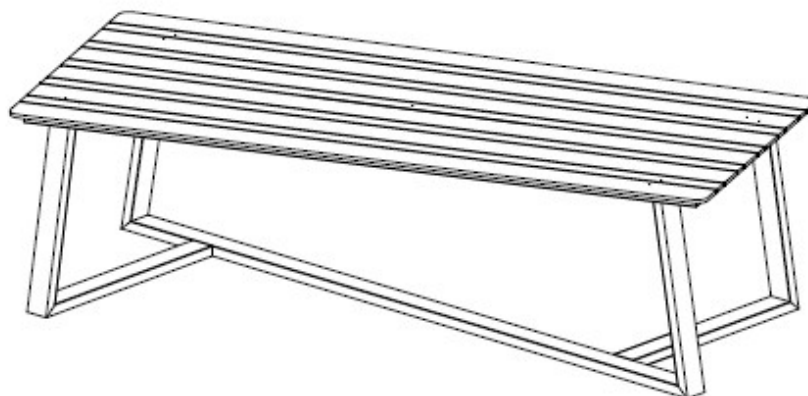

STEP 2: Tighten all the bolts and cover with the bolt caps (G), then turn over the table.



Assembly Instructions

Alora Side Table (61111091/61111099)









**PLEASE RETAIN THIS DOCUMENT ALONG WITH YOUR PROOF
OF PURCHASE FOR FUTURE REFERENE**

Congratulations on your recent purchase of your beautiful Hartman furniture. We hope it brings you bountiful special moments with friends and family for many years to come. Please follow these simple steps to build your furniture. We also have a very useful video available online to assist with the assembly, please visit www.hartmanuk.com

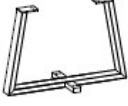
TOP TIPS

- Please read these instructions carefully before assembly. For further assistance please view our assembly video online for an easy step by step demonstration.
- Aluminium is a soft metal and over tightening may strip the thread or break the part, please loosely assemble your furniture before tightening to secure.
- Please **do not** use power tools, please only use the tools provided in the bolt pack.
- Please allow 1 hour for assembly.
- This furniture can be assembled by 1 person; however, you may need someone to assist you when turning the furniture over into position.

PARTS LIST

Components					Fixings				
Parts List	Parts Picture	Description	Qty	Part No.	Parts List	Parts Picture	Description	Qty	Part No.
A		Table Top	1	61111091A 61111099A	D		M6x15 Bolt	12	1011162
B		Leg 1	1	61111091B 61111099B	E		M6x16 Washer	12	1061162
C		Leg 2	2	61111091C 61111099C	F		M6 Allen Key	1	1010162
					G		Bolt Cap	12	1061163
					H		Adjustable Foot	4	1061179

STEP 1: LEGS ASSEMBLY

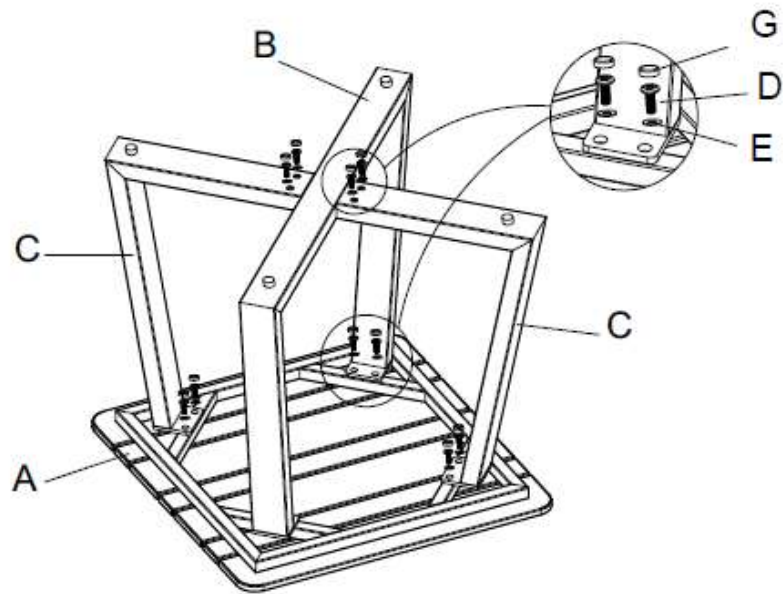

STEP 1: Attach leg2 (C) to the leg1 (B), using the bolt M6x15 (D) and Washer (E)
Then attach the leg to the table top (A), using the bolt M6x15 (D) and Washer (E).

STEP 2: FINISHING

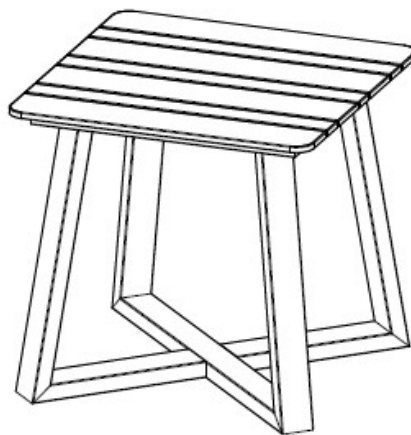

STEP 2: Tighten all the bolts and cover with the bolt caps (G), then turn over the table.