



Assembly Instructions

Arley 3 Seat Lounge Set

(Product Codes: 68815158, 68818158 & 68819158)

**PLEASE RETAIN THIS DOCUMENT ALONG WITH YOUR
PROOF OF PURCHASE FOR FUTURE REFERENCE**

Congratulations on your recent purchase of your beautiful Hartman furniture. We hope it brings you countless special moments with friends and family for many years to come.

Please follow these simple steps to build your furniture. We also have a very useful video available online to assist with the assembly, please visit www.hartmanuk.com

TOP TIPS

- Please read these instructions carefully before assembly, for further assistance please view our assembly video online for an easy step by step demonstration.
- Aluminium is a soft metal and over tightening may strip the thread or break the part, please loosely assembly your furniture before tightening to secure.
- Please **do not** use power tools, only use the tools provided in the bolt pack.
- Please allow 1 hour for assembly.
- This furniture can be assembled with **1** person; however, you may need someone to assist you when turning the furniture over into position.



Assembly Instructions

Arley 3 Seat Sofa & 2 x Lounge Chairs

(Product Codes: 68815158)

**PLEASE RETAIN THIS DOCUMENT ALONG WITH YOUR
PROOF OF PURCHASE FOR FUTURE REFERENCE**







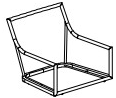

Congratulations on your recent purchase of your beautiful Hartman furniture. We hope it brings you countless special moments with friends and family for many years to come.

Please follow these simple steps to build your furniture. We also have a very useful video available online to assist with the assembly, please visit www.hartmanuk.com

TOP TIPS

- Please read these instructions carefully before assembly, for further assistance please view our assembly video online for an easy step by step demonstration.
- Aluminium is a soft metal and over tightening may strip the thread or break the part, please loosely assembly your furniture before tightening to secure.
- Please **do not** use power tools, only use the tools provided in the bolt pack.
- Please allow 1 hour for assembly.
- This furniture can be assembled with **1** person; however, you may need someone to assist you when turning the furniture over into position.

PARTS LIST - LOUNGE CHAIR

Components					Fixings				
Parts List	Parts Picture	Description	Qty	Part No	Parts List	Parts Picture	Description	Qty	Part No
A		Lounge Chair Seat Frame	1	68815158A	E		M6x50 Bolts	8	2002162
B		Lounge Chair Front Leg	1	68815158B	F		Big Flat Washers	8	1060162
C		Lounge Chair Rear Leg	1	68815158C	G		Allen Key	1	2002191
D		Lounge Chair Connecting Tube	2	68815158D					
H		Lounge Chair Seat Cushion	1	68815158H					
I		Lounge Chair Back Cushion	1	68815158I					

STEP 1, 2 & 3: LEG ASSEMBLY

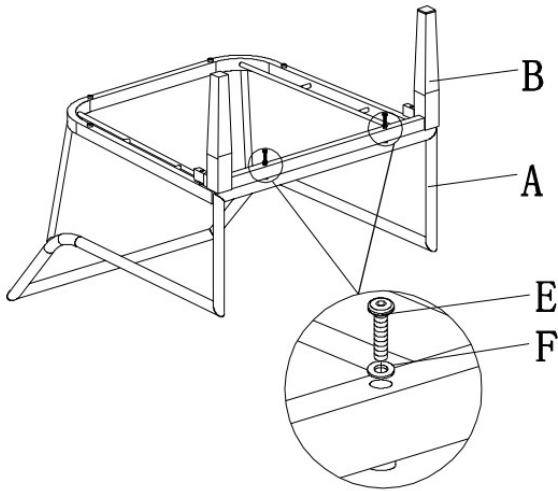

STEP 1: Loosely attach front leg frame (B) to seating frame (A) with bolts (E) and big flat washers (F) using Allen key (G).

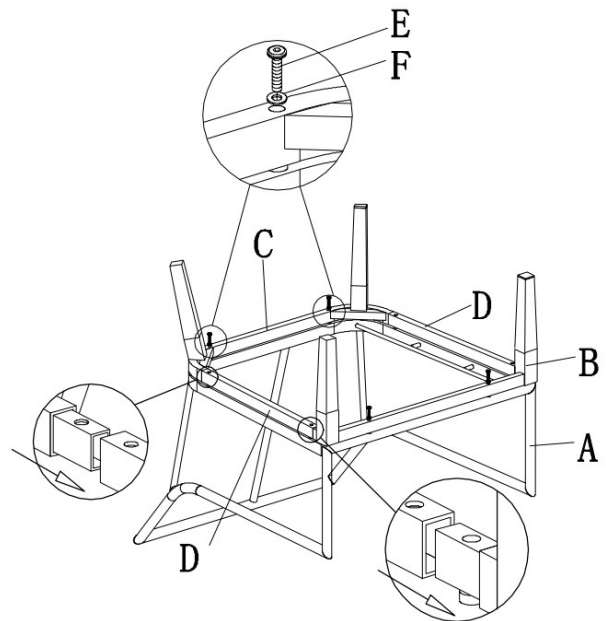

STEP 2: Insert connecting tubes (D) to rear leg tube (C), loosely attach rear leg frame (C) to the seating frame with bolts (E) and big flat washers (F) using Allen key (G).

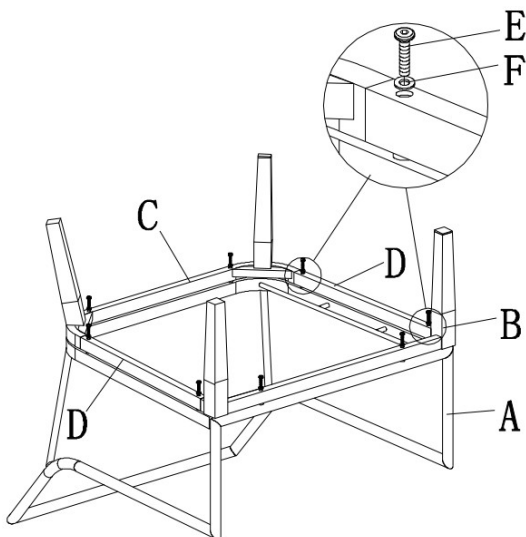

STEP 3: Loosely attach the connecting tubes (D) to seating frame with bolts (E) and big flat washers (F) using Allen key (G).



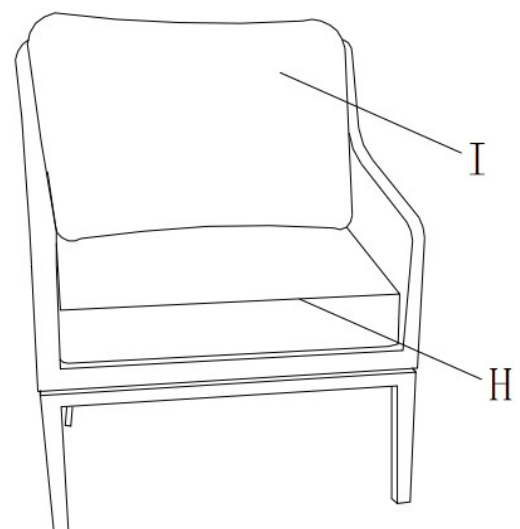





Tighten all bolts using Allen key (G) one by one being careful not to over tighten any as this will cause the thread to become damaged.

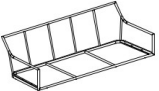

STEP 4: Turn the chair over and place in desired position. Put seat cushion (H) and back cushion (I) on the seat.

You can now use the chair.

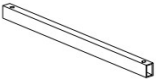
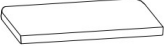
PARTS LIST - 3 SEAT SOFA

Components					Fixings				
Parts List	Parts Picture	Description	Qty	Part No	Parts List	Parts Picture	Description	Qty	Part No
A		3 Seat Sofa Seat Frame	1	68815158A1	E		M6x50 Bolts	12	2002162
B		3 Seat Sofa Front Leg	1	68815158B1	F		Big Flat Washers	12	1060162
C		3 Seat Sofa Rear Leg	1	68815158C1	G		Allen Key	1	2002191
D		3 Seat Sofa Connecting Tube	2	68815158D1					
H		3 Seat Sofa Seat Cushion	1	68815158H1					
I		3 Seat Sofa Back Cushion	3	68815158I1					

STEP 1, 2 & 3: LEG ASSEMBLY

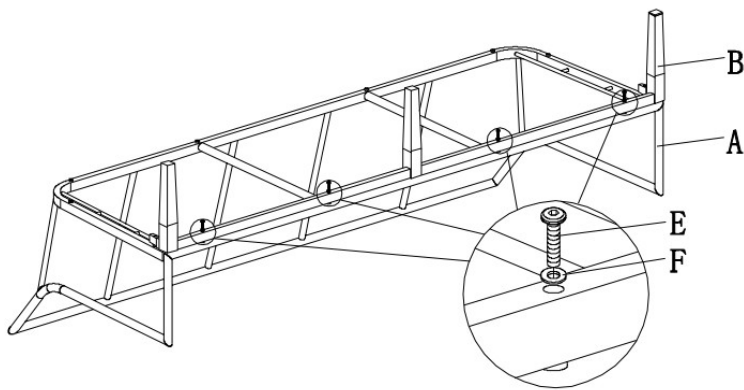

STEP 1: Loosely attach front leg frame (B) to seating frame (A) with bolts (E) and big flat washers (F) using Allen key (G).

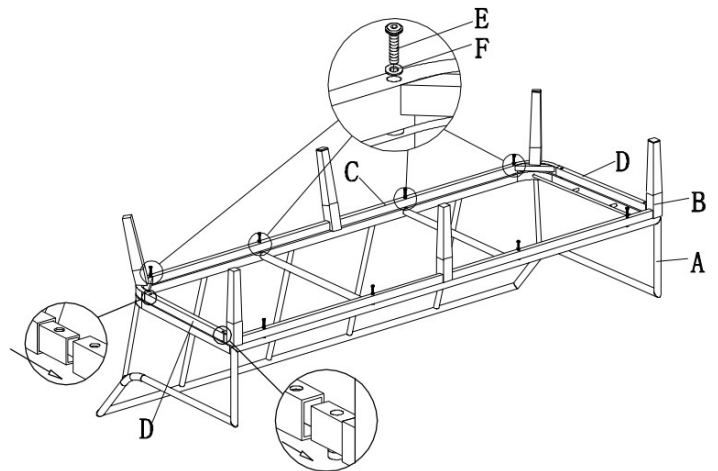

STEP 2: Insert connecting tubes (D) to rear leg tube (C), loosely attach rear leg frame (C) to the seating frame with bolts (E) and big flat washers (F) using Allen key (G).

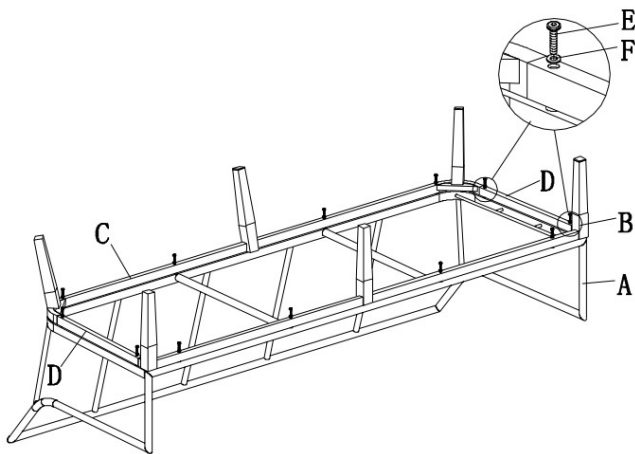

STEP 3: Loosely attach the connecting tubes (D) to seating frame with bolts (E) and big flat washers (F) using Allen key (G).

Tighten all bolts using Allen key (G) one by one being careful not to over tighten any as this will cause the thread to become damaged.

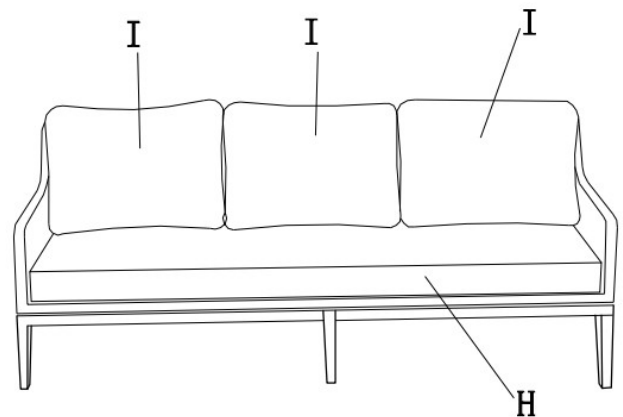

STEP 4: Turn the sofa over and place in desired position. Put seat cushion (H) and back cushions (I) on the seat.

You can now use the sofa.



Assembly Instructions

Arley Rectangular Adjustable Table

(Product Codes: 68818158 & 68819158)

**PLEASE RETAIN THIS DOCUMENT ALONG WITH YOUR
PROOF OF PURCHASE FOR FUTURE REFERENCE**







Congratulations on your recent purchase of your beautiful Hartman furniture. We hope it brings you countless special moments with friends and family for many years to come.

Please follow these simple steps to build your furniture. We also have a very useful video available online to assist with the assembly, please visit www.hartmanuk.com

TOP TIPS

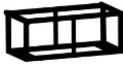
- Please read these instructions carefully before assembly, for further assistance please view our assembly video online for an easy step by step demonstration.
- Aluminium is a soft metal and over tightening may strip the thread or break the part, please loosely assembly your furniture before tightening to secure.
- Please **do not** use power tools, only use the tools provided in the bolt pack.
- Please allow 1 hour for assembly.
- This furniture can be assembled with **1** person; however, you may need someone to assist you when turning the furniture over into position.

PARTS LIST

Components					Fixings				
Parts List	Parts Picture	Description	Qty	Part No	Parts List	Parts Picture	Description	Qty	Part No
A		Table Top Frame	1	68818158A	D		M6*40 Bolts	4	1006162
B		Connecting Section	1	68819158B	E		M6 Flat Washers	4	1061162
C		Table Base	1	68819158C	F		Allen Key	1	2002191

STEP 1 & 2: TABLE TOP AND BASE ASSEMBLY

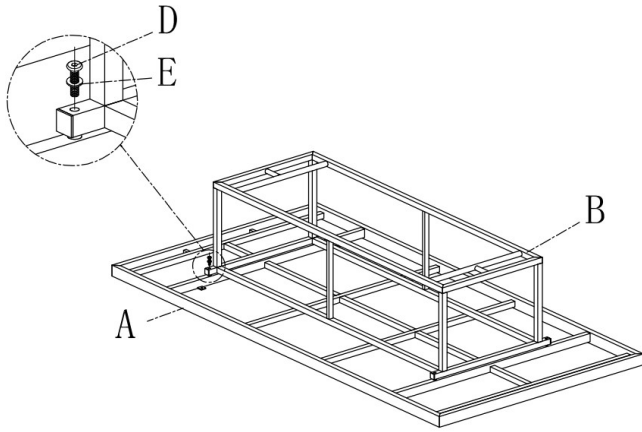

STEP 1: Attach middle connection section (B) to table top (A) using bolts (D) and washers (E), tighten all bolts using the Allen key (F).

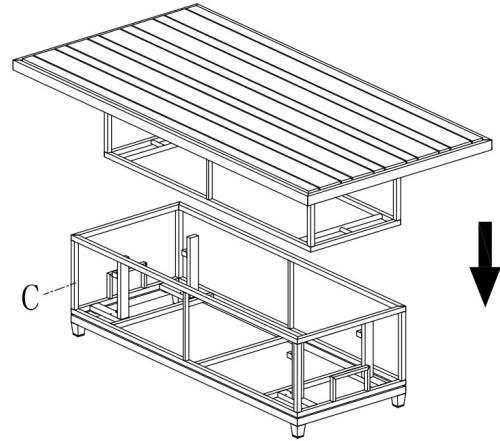

STEP 2: Turn assembled top over and prepare well bottom base (C) for assembling.

STEP 3: FIX THE BASE

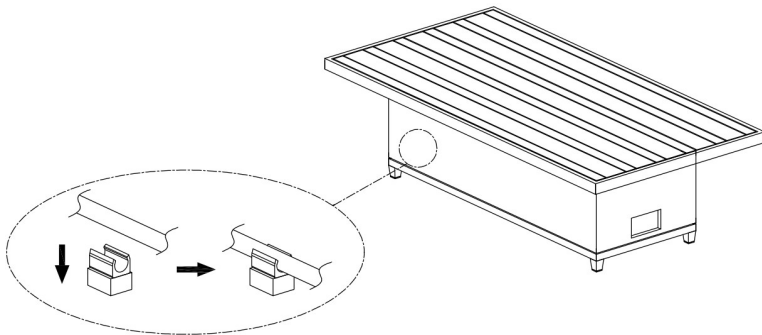

STEP 3: Place assembled table top into the bottom base (C) until it clicks into place.

ADJUSTING THE HEIGHT OF THE TABLE:

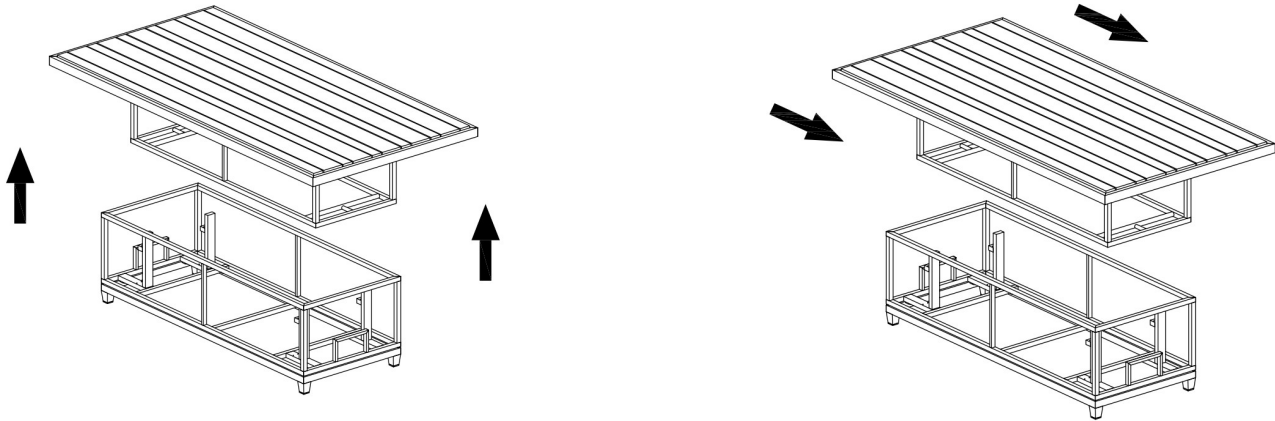

STEP 1: Lift the table top and move slide forward until you feel the top clip into the high adjustment, or to lower table height, lift the table top a little bit and move backward to the left direction to adjust to the lowered height.

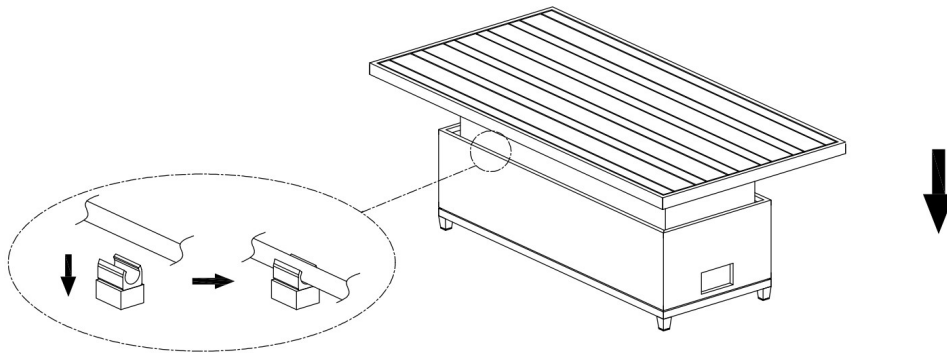

STEP 2: Once it is in the correct position for your desired table height, gently place the table top back into the slot of the base frame

ADJUSTMENT INSTRUCTIONS

1. For a rectangular adjustable table, two people are needed.
2. Place foot into the step at the bottom of the table base to stop the table from moving when making the adjustment.
3. Place hands on either side of the table top and gently pull until you feel the table unclip from the base frame.
4. Lift the table top and move slide forward until you feel the top clip into the high adjustment, or to lower table height, lift up the table top a little bit and move backward to the left direction to adjust to the lowered height.
5. Once it is in the correct position for your desired table height, gently place the table top back into the slot of the base frame.
6. Holding the table top at either side, gently push until you feel it click back securely into the base frame.
7. Make sure the table top is securely and evenly in place before use. If the table top is not correctly in place, repeat steps 2 to 6 until you are happy the table top is secure and at your desired height.