



# Assembly Instructions

## Sonas 2 Seat Lounge Set

(Product Codes: 69106062, 69160062 & 69117062)

**PLEASE RETAIN THIS DOCUMENT ALONG WITH YOUR  
PROOF OF PURCHASE FOR FUTURE REFERENCE**

Congratulations on your recent purchase of your beautiful Hartman furniture. We hope it brings you countless special moments with friends and family for many years to come.

Please follow these simple steps to build your furniture. We also have a very useful video available online to assist with the assembly, please visit [www.hartmanuk.com](http://www.hartmanuk.com)

### TOP TIPS

- Please read these instructions carefully before assembly, for further assistance please view our assembly video online for an easy step by step demonstration.
- Aluminium is a soft metal and over tightening may strip the thread or break the part, please loosely assembly your furniture before tightening to secure.
- Please **do not** use power tools, only use the tools provided in the bolt pack.
- Please allow 1 hour for assembly.
- This furniture can be assembled with **1** person; however, you may need someone to assist you when turning the furniture over into position.



# Assembly Instructions

## **Sonas 2 Seat Sofa** **(Product Codes: 69108062 / 69108018)**

**PLEASE RETAIN THIS DOCUMENT ALONG WITH YOUR  
PROOF OF PURCHASE FOR FUTURE REFERENCE**









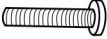

Congratulations on your recent purchase of your beautiful Hartman furniture. We hope it brings you countless special moments with friends and family for many years to come.

Please follow these simple steps to build your furniture. We also have a very useful video available online to assist with the assembly, please visit [www.hartmanuk.com](http://www.hartmanuk.com)

### **TOP TIPS**

- Please read these instructions carefully before assembly, for further assistance please view our assembly video online for an easy step by step demonstration.
- Aluminum is a soft metal and over tightening may strip the thread or break the part, please loosely assembly your furniture before tightening to secure.
- Please **do not** use power tools, only use the tools provided in the bolt pack.
- Please allow 1 hour for assembly.
- This furniture can be assembled with **2** people; however, you may need someone to assist you when turning the furniture over into position.

# PARTS LIST

Components					Fixings				
Parts List	Parts Picture	Description	Qty	Part No.	Parts List	Parts Picture	Description	Qty	Part No.
A		Seat Frame	1	69108062A 69108018A	G		M6 φ16 Washer	7	1061162
B		Armrest 1	1	69108062B 69108018B	H		M6x35 Bolt	7	1111162
C		Armrest 2	1	69108062C 69108018C	I		Plastic Bolt Cap	9	1061163
D		Back Rest	1	69108062D 69108018D	J		M6 Allen Key	1	1010162
E		Back Cushion	2	69108062E 69108018E	K		M6x55 Bolt	2	1641162
F		Seat Cushion	2	69108062F 69108018F	L		Adjustable Footpad	2	2PIF001

## STEP 1 & 2: ARMREST ASSEMBLY

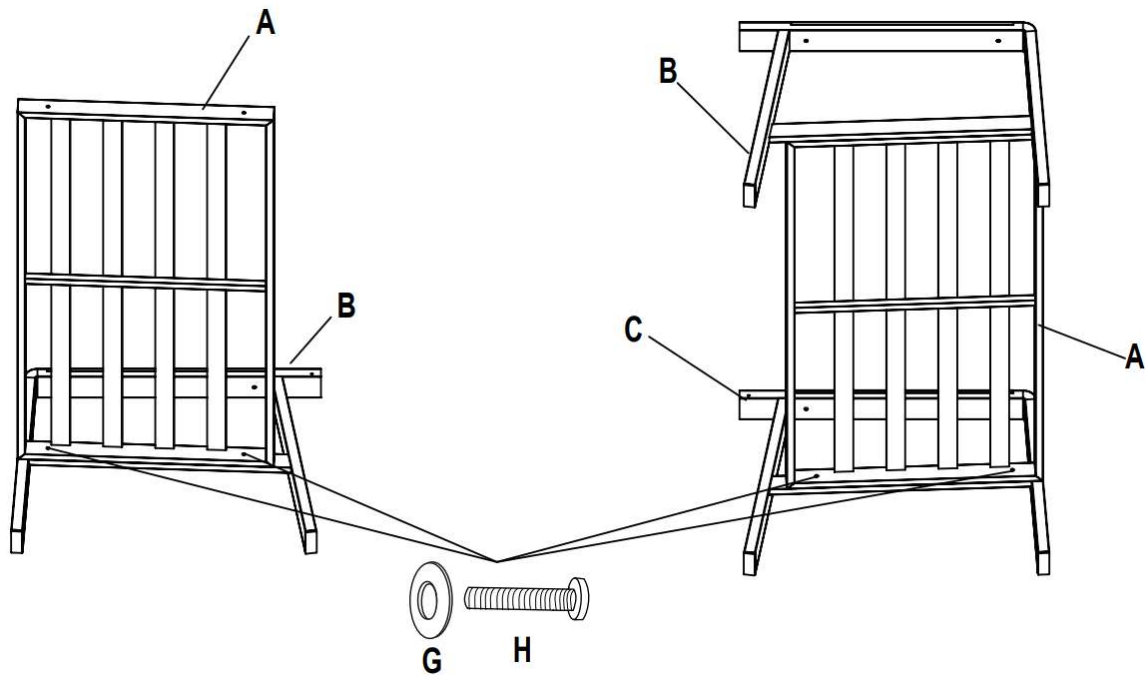

- STEP 1:** Attach Armrest 1 (B) to the Seat Frame (A) using the M6x35 Bolt (H) and Washer (G)  
**STEP 2:** Repeat step 1 with Armrest 2 (C)

## STEP 3 & 4: BACKREST ASSEMBLY

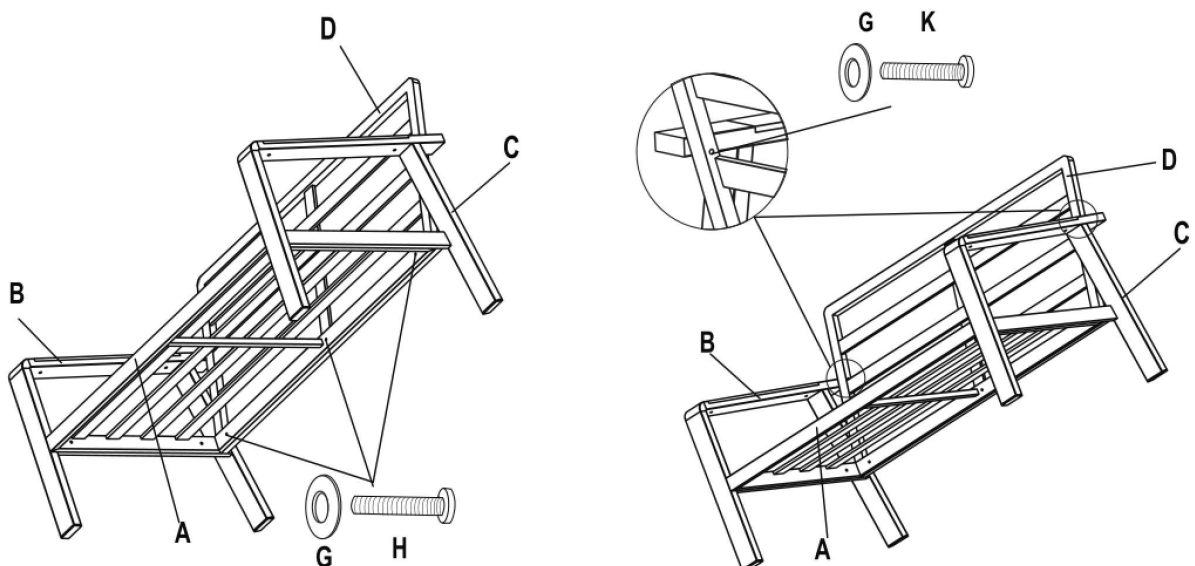

- STEP 3:** Attach Back Rest (D) to the Seat Frame (A) using the M6x35 Bolt (H) and Washer (G)  
**STEP 4:** Attach the Back Rest (D) to Armrest 1 (B) & Armrest 2 (C) using the M6x55 Bolt (K) and Washer (G)

## STEP 5: TIGHTENING AND FINISHING

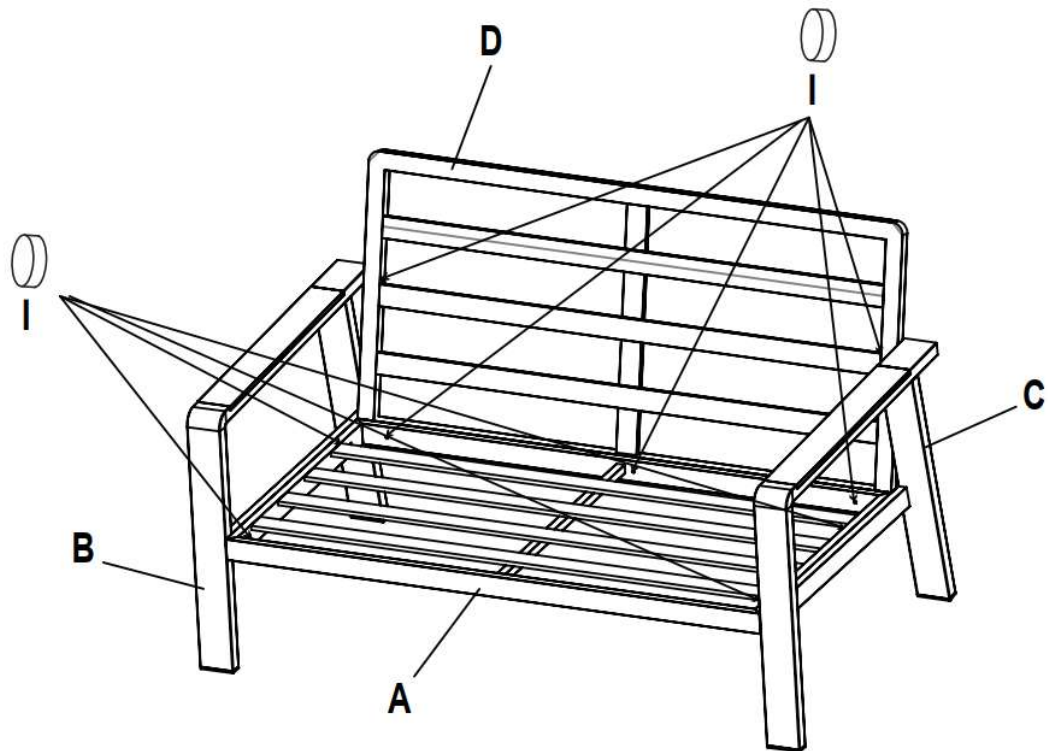

**STEP 5:** Tighten all the bolts on the sofa and cover with the Plastic bolt cap (I).  
Turn the sofa over and place the Seat cushion (F) and the Back cushion (E)  
onto the sofa



# Assembly Instructions

## **Sonas Lounge Chair (69106062 & 69160062 / 69106018 & 69106118)**

**PLEASE RETAIN THIS DOCUMENT ALONG WITH YOUR  
PROOF OF PURCHASE FOR FUTURE**









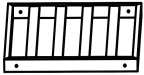

Congratulations on your recent purchase of your beautiful Hartman furniture. We hope it brings you countless special moments with friends and family for many years to come.

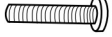
Please follow these simple steps to build your furniture. We also have a very useful video available online to assist with the assembly, please visit [www.hartmanuk.com](http://www.hartmanuk.com)

### **TOP TIPS**

- Please read these instructions carefully before assembly, for further assistance please view our assembly video online for an easy step by step demonstration.
- Aluminium is a soft metal and over tightening may strip the thread or break the part, please loosely assembly your furniture before tightening to secure.
- Please **do not** use power tools, only use the tools provided in the bolt pack.
- Please allow 1 hour for assembly.
- This furniture can be assembled with **1** person; however, you may need someone to assist you when turning the furniture over into position

# PARTS LIST

Components					Fixings				
Parts List	Parts Picture	Description	Qty	Part No.	Parts List	Parts Picture	Description	Qty	Part No.
A		Seat Frame	1	69106062A 69106018A	G		Washer (M6*φ16)	8	1061162
B		Armrest 1	1	69106062B 69106018B	H		M6x35 Bolt	6	1111162
C		Armrest 2	1	69106062C 69106018C	I		Plastic Bolt Cap	8	1061163
D		Back Rest	1	69106062D 69106018D	J		M6 Allen Key	1	1010162
E		Back Cushion	1	69106062E 69106018E	K		M6x55 Bolt	2	1641162
F		Seat Cushion	1	69106062F 69106018F	L		Footpad	4	2PIF001

## STEP 1 & 2: ARMREST ASSEMBLY

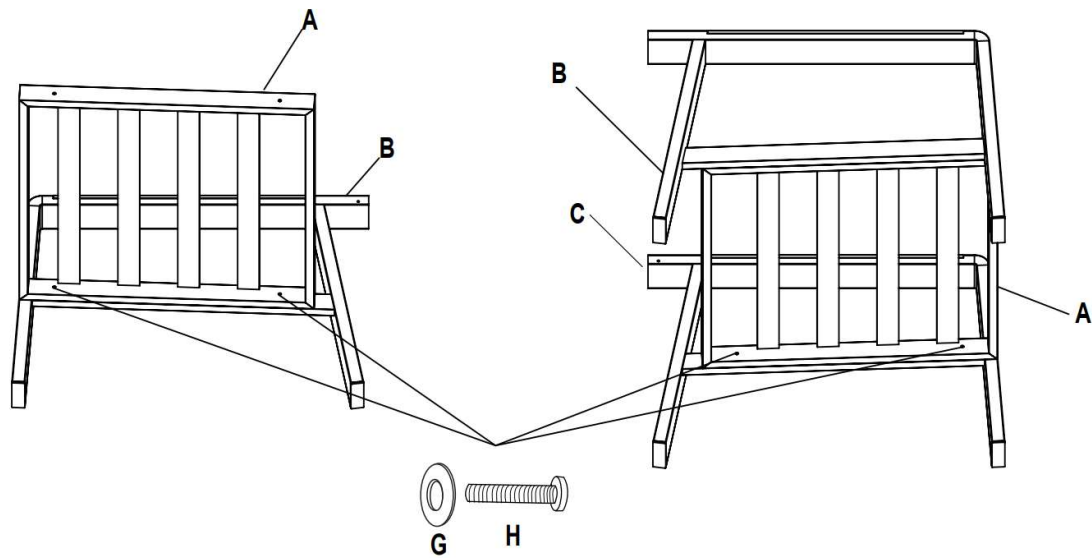

**STEP 1:** Attach Armrest 1 (B) to the Seat Frame (A) using the M6x35 Bolt (H) and Washer (G)  
**STEP 2:** Repeat step 1 with Armrest 2 (C)

## STEP 3 & 4: BACKREST ASSEMBLY

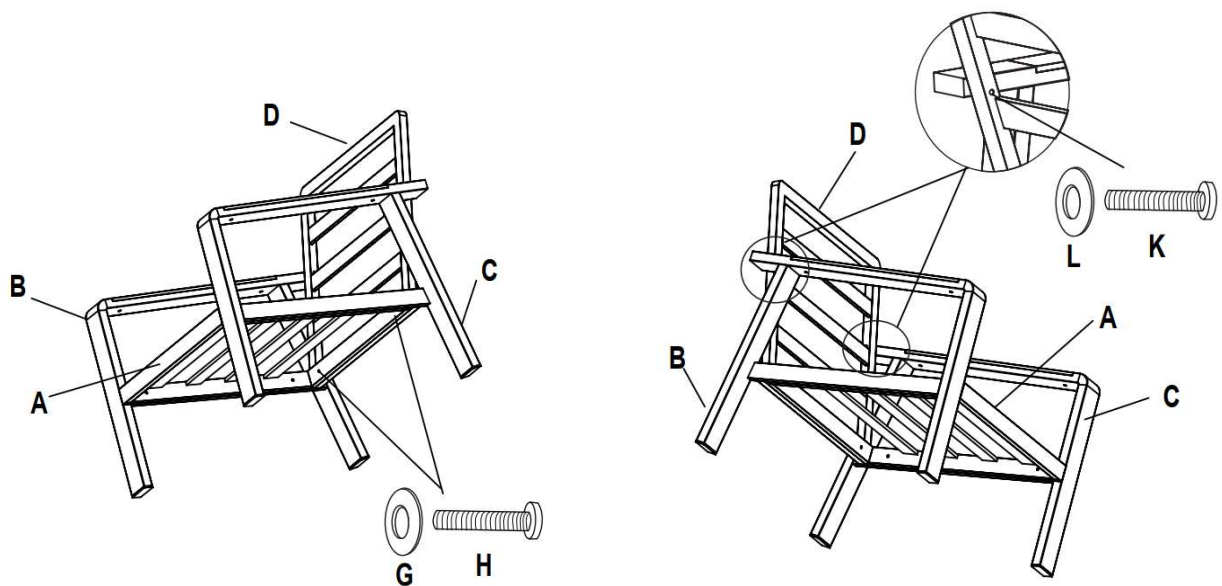

**STEP 3:** Attach Back Rest (D) to the Seat Frame (A) using the M6x35 Bolt (H) and Washer (G)  
**STEP 4:** Attach the Back Rest (D) to Armrest 1 (B) & Armrest 2 (C) using the M6x55 Bolt (K) and Washer (L)

## STEP 5: TIGHTENING AND FINISHING

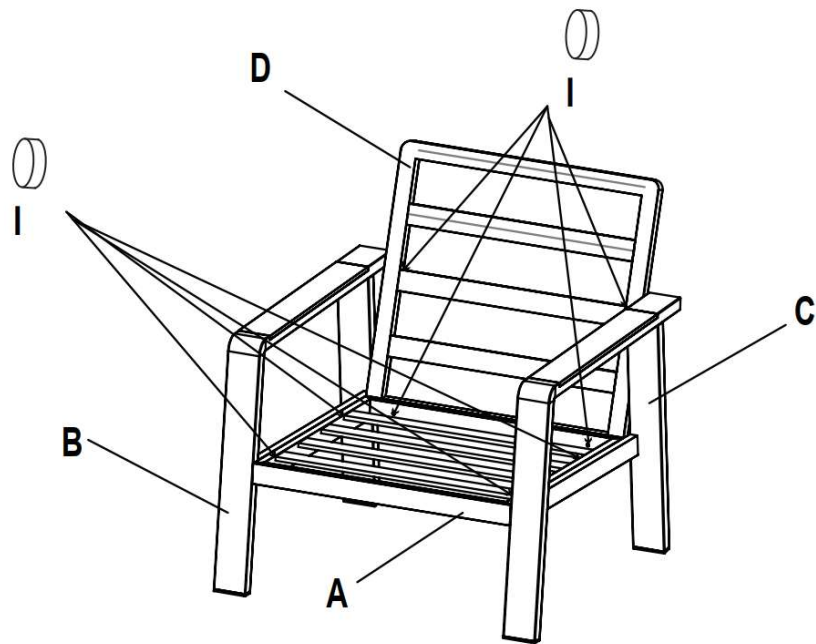

**STEP 5:** Tighten all the bolts on the chair and cover with the Plastic bolt cap (I).  
Turn the chair over and place the Seat cushion (F) and the Back cushion (E) onto the chair.



# Assembly Instructions

## **Sonas 120x75cm Rectangular Coffee Table**

**(Product Code: 69117062)**









**PLEASE RETAIN THIS DOCUMENT ALONG WITH YOUR  
PROOF OF PURCHASE FOR FUTURE REFERENCE**

Congratulations on your recent purchase of your beautiful Hartman furniture. We hope it brings you bountiful special moments with friends and family for many years to come. Please follow these simple steps to build your furniture. We also have a very useful video available online to assist with the assembly, please visit [www.hartmanuk.com](http://www.hartmanuk.com)

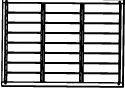
### **TOP TIPS**

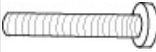
- Please read these instructions carefully before assembly. For further assistance please view our assembly video online for an easy step by step demonstration.
- Aluminium is a soft metal and over tightening may strip the thread or break the part, please loosely assemble your furniture before tightening to secure.
- Please **do not** use power tools, please only use the tools provided in the bolt pack.
- Please allow 1 hour for assembly.
- This furniture can be assembled with **1** person; however, you may need someone to assist you when turning the furniture over into position.

# PARTS LIST

Components					Fixings				
Parts List	Parts Picture	Description	Qty	Part No.	Parts List	Parts Picture	Description	Qty	Part No.
A		Table Leg	2	69117062A	J		Washer M6x $\phi$ 16		1061166
B		Table Top	1	69117062B	K		Bolt M6x20		1091162
C					L		Bolt M6x40		1121162
D					M		Bolt Cap		1061163
							M6 Allen Key		1010162
							Adjustable Foot Pad		2PNSF001

## STEP 1 & 2: LEG ASSEMBLY

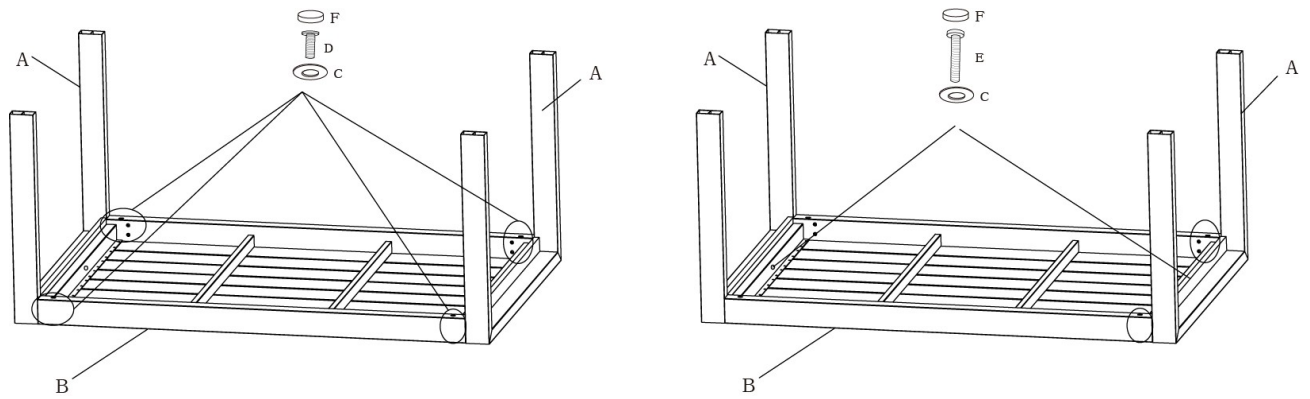

**STEP 1:** Attach leg (A) to the table top (B) using the M6x20 bolt (D) and washer (C)

**STEP 2:** Then using the M6x40 bolt (E) and washer (C)

## STEP 3: TIGHTEN AND FINISHING

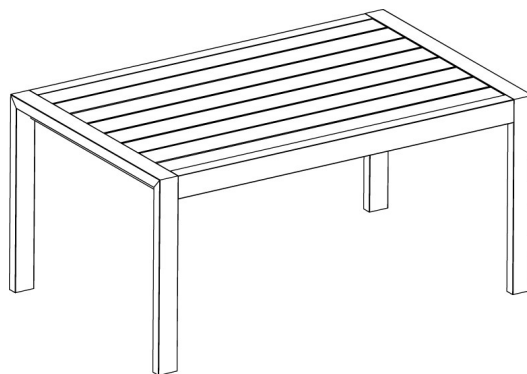

**STEP 3:** Finally tighten all the bolts and add the bolt caps (F) to the bolts.