



Assembly Instructions

Sonas 3 Seat Lounge Set with Rectangular Adjustable Table

(Product Codes: 69106062, 69160062,
69125062, 69126062 & 69104062)

**PLEASE RETAIN THIS DOCUMENT ALONG WITH YOUR
PROOF OF PURCHASE FOR FUTURE REFERENCE**

Congratulations on your recent purchase of your beautiful Hartman furniture. We hope it brings you countless special moments with friends and family for many years to come.

Please follow these simple steps to build your furniture. We also have a very useful video available online to assist with the assembly, please visit www.hartmanuk.com

TOP TIPS

- Please read these instructions carefully before assembly, for further assistance please view our assembly video online for an easy step by step demonstration.
- Aluminium is a soft metal and over tightening may strip the thread or break the part, please loosely assembly your furniture before tightening to secure.
- Please **do not** use power tools, only use the tools provided in the bolt pack.
- Please allow 1 hour for assembly.



Assembly Instructions

Sonas 3 Seat Sofa

(Product Codes: 69121062 / 69121018)

**PLEASE RETAIN THIS DOCUMENT ALONG WITH YOUR
PROOF OF PURCHASE FOR FUTURE**











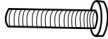
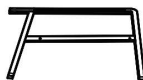

Congratulations on your recent purchase of your beautiful Hartman furniture. We hope it brings you countless special moments with friends and family for many years to come.

Please follow these simple steps to build your furniture. We also have a very useful video available online to assist with the assembly, please visit www.hartmanuk.com

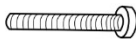
TOP TIPS

- Please read these instructions carefully before assembly, for further assistance please view our assembly video online for an easy step by step demonstration.
- Aluminium is a soft metal and over tightening may strip the thread or break the part, please loosely assemble your furniture before tightening to secure.
- Please **do not** use power tools, only use the tools provided in the bolt pack.
- Please allow 1 hour for assembly.
- This furniture can be assembled with **2** people; however, you may need someone to assist you when turning the furniture over into position.

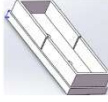
PARTS LIST

| Components | | | | | Fixings | | | | |
|------------|---|-----------------|-----|------------------------|------------|---|-----------------------|-----|----------|
| Parts List | Parts Picture | Description | Qty | Part No. | Parts List | Parts Picture | Description | Qty | Part No. |
| A |  | Seat Frame | 1 | 69121062A 69121018A | H |  | Washer (M6*φ16) | 10 | 1061162 |
| B |  | Armrest 1 | 1 | 69121062B 69121018B | I |  | M6x35 Bolt | 8 | 1111162 |
| C |  | Armrest 2 | 1 | 69121062C 69121018C | J |  | Plastic Bolt Cap | 12 | 1061163 |
| D |  | Back Rest | 1 | 69121062D 69121018D | K |  | M6 Allen Key | 1 | 1010162 |
| E |  | Centre Leg | 1 | 69121062E 69121018E | L |  | M6x55 Bolt | 2 | 1641162 |
| F |  | Back Cushion | 3 | 69121062F 69121018F | M |  | Washer (M6*φ12) | 2 | 1241162 |
| G |  | Seat Cushion | 3 | 69121062G 69121018G | N |  | M6x20 Bolt | 2 | 1091162 |
| | | | | | O |  | Footpad | 4 | 2PIF001 |
| | | | | | P |  | Adjustable Footpad | 1 | 2PIF004 |

STEP 1 & 2: ARMREST ASSEMBLY

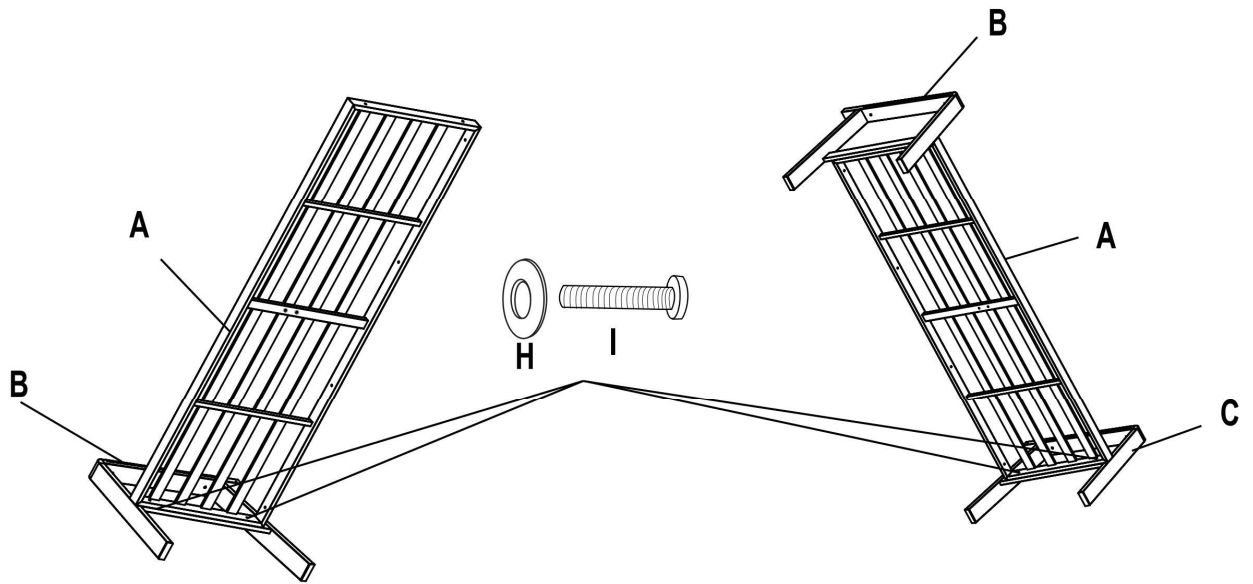

STEP 1: Attach Armrest 1 (B) to the Seat Frame (A) using the M6x35 Bolt (I) and Washer (H)
STEP 2: Repeat step 1 with Armrest 2 (C)

STEP 3 & 4: BACKREST AND LEG ASSEMBLY

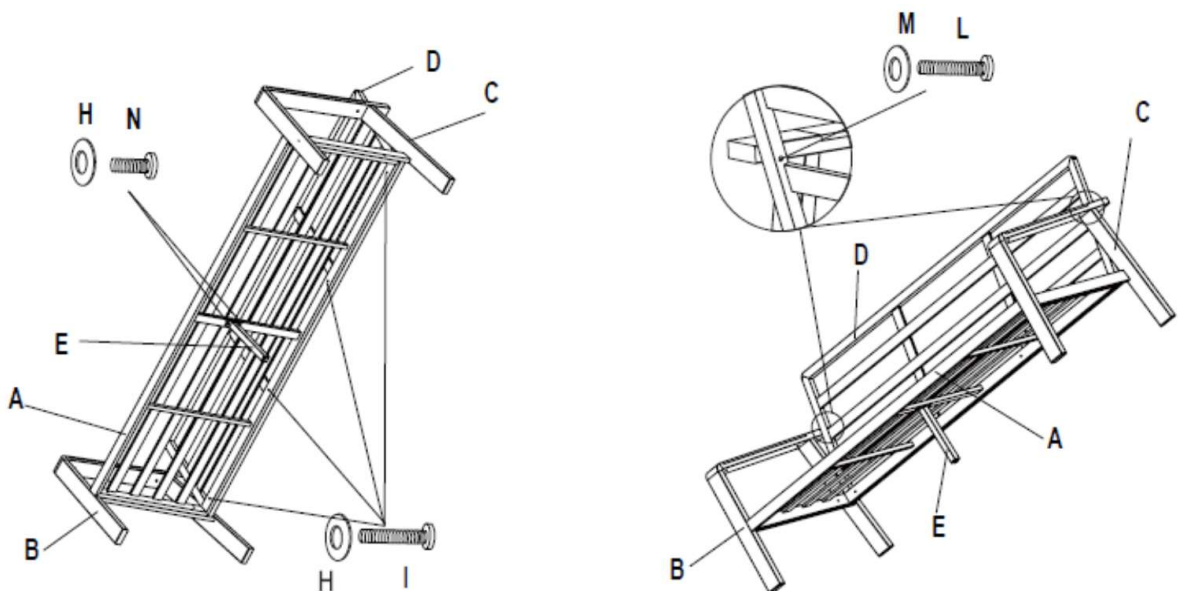

STEP 3: Attach Back Rest (D) to the Seat Frame (A) using the M6x35 Bolt (I) and Washer (H).
Attach Centre leg(E) to Seat Frame (A) using the M6x20 Bolt (N) and Washer (H)
STEP 4: Attach Back Rest (D) to Armrest 1 (B) & Armrest 2 (C) using the M6x55 Bolt (L) and Washer (M),

STEP 5: TIGHTENING AND FINISHING

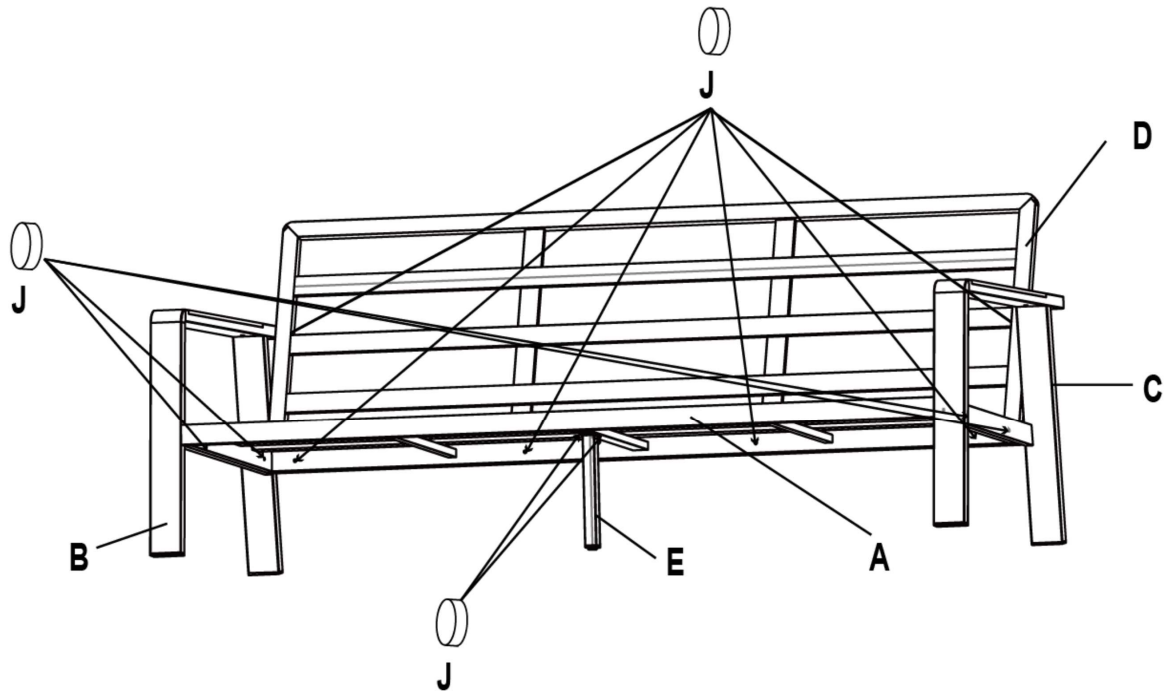

STEP 5: Tighten all the bolts on the sofa and cover with the Plastic bolt cap (J). Turn the sofa over and place the Seat cushion (G) and the Back cushion (F) onto the sofa



Assembly Instructions

Sonas Lounge Chair (69106062 & 69160062 / 69106018 & 69106118)

**PLEASE RETAIN THIS DOCUMENT ALONG WITH YOUR
PROOF OF PURCHASE FOR FUTURE**









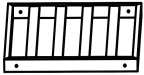

Congratulations on your recent purchase of your beautiful Hartman furniture. We hope it brings you countless special moments with friends and family for many years to come.

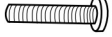
Please follow these simple steps to build your furniture. We also have a very useful video available online to assist with the assembly, please visit www.hartmanuk.com

TOP TIPS

- Please read these instructions carefully before assembly, for further assistance please view our assembly video online for an easy step by step demonstration.
- Aluminium is a soft metal and over tightening may strip the thread or break the part, please loosely assembly your furniture before tightening to secure.
- Please **do not** use power tools, only use the tools provided in the bolt pack.
- Please allow 1 hour for assembly.
- This furniture can be assembled with **1** person; however, you may need someone to assist you when turning the furniture over into position

PARTS LIST

| Components | | | | | Fixings | | | | |
|------------|---|-----------------|-----|------------------------|------------|---|---------------------|-----|----------|
| Parts List | Parts Picture | Description | Qty | Part No. | Parts List | Parts Picture | Description | Qty | Part No. |
| A |  | Seat Frame | 1 | 69106062A 69106018A | G |  | Washer (M6*φ16) | 8 | 1061162 |
| B |  | Armrest 1 | 1 | 69106062B 69106018B | H |  | M6x35 Bolt | 6 | 1111162 |
| C |  | Armrest 2 | 1 | 69106062C 69106018C | I |  | Plastic Bolt Cap | 8 | 1061163 |
| D |  | Back Rest | 1 | 69106062D 69106018D | J |  | M6 Allen Key | 1 | 1010162 |
| E |  | Back Cushion | 1 | 69106062E 69106018E | K |  | M6x55 Bolt | 2 | 1641162 |
| F |  | Seat Cushion | 1 | 69106062F 69106018F | L |  | Footpad | 4 | 2PIF001 |

STEP 1 & 2: ARMREST ASSEMBLY

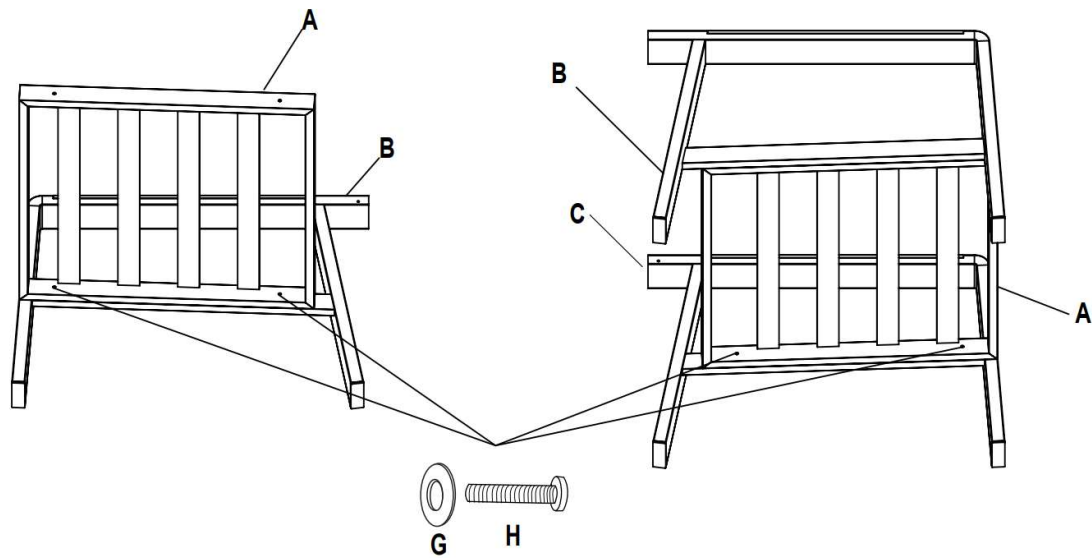

STEP 1: Attach Armrest 1 (B) to the Seat Frame (A) using the M6x35 Bolt (H) and Washer (G)
STEP 2: Repeat step 1 with Armrest 2 (C)

STEP 3 & 4: BACKREST ASSEMBLY

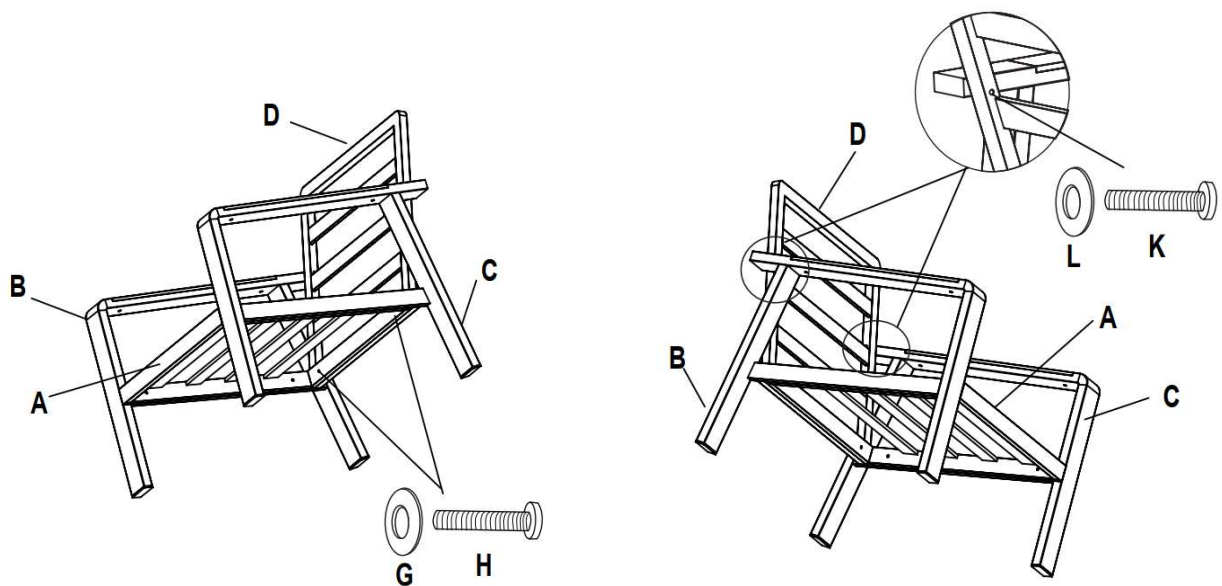

STEP 3: Attach Back Rest (D) to the Seat Frame (A) using the M6x35 Bolt (H) and Washer (G)
STEP 4: Attach the Back Rest (D) to Armrest 1 (B) & Armrest 2 (C) using the M6x55 Bolt (K) and Washer (L)

STEP 5: TIGHTENING AND FINISHING

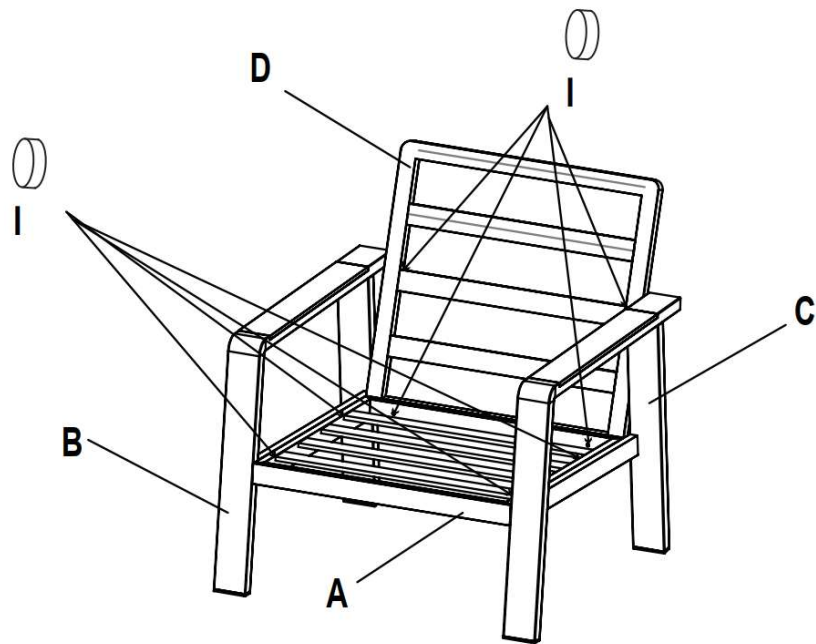

STEP 5: Tighten all the bolts on the chair and cover with the Plastic bolt cap (I).
Turn the chair over and place the Seat cushion (F) and the Back cushion (E) onto the chair.



Assembly Instructions

Sonas 150x90cm Rectangular Adjustable Table

(Product Codes: 69125062 & 69126062)













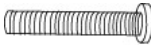

**PLEASE RETAIN THIS DOCUMENT ALONG WITH YOUR
PROOF OF PURCHASE FOR FUTURE REFERENCE**

Congratulations on your recent purchase of your beautiful Hartman furniture. We hope it brings you bountiful special moments with friends and family for many years to come. Please follow these simple steps to build your furniture. We also have a very useful video available online to assist with the assembly, please visit www.hartmanuk.com

TOP TIPS

- Please read these instructions carefully before assembly. For further assistance please view our assembly video online for an easy step by step demonstration.
- Aluminium is a soft metal and over tightening may strip the thread or break the part, please loosely assemble your furniture before tightening to secure.
- Please **do not** use power tools, please only use the tools provided in the bolt pack.
- Please allow **1 hour** for assembly
- This furniture can be assembled with **2** people; however, you may need someone to assist you when turning the furniture over into position.

PARTS LIST

| Components | | | | | Fixings | | | | |
|------------|---|-------------|-----|-----------|------------|---|--------------------|-----|----------|
| Parts List | Parts Picture | Description | Qty | Part No. | Parts List | Parts Picture | Description | Qty | Part No. |
| A |  | Table Top | 1 | 69125062A | D |  | M6x25 Bolt | 8 | 1017162 |
| B |  | Leg Pillar | 1 | 69126062B | E |  | M6x35 Bolt | 2 | 1111162 |
| C |  | Table Base | 1 | 69125062C | F |  | M8x55 Bolt | 8 | 2002166 |
| | | | | | G |  | M6φ12 Washer | 10 | 1241162 |
| | | | | | H |  | M8φ20 Washer | 8 | 1061191 |
| | | | | | I |  | M6 Bolt Cap | 10 | 1061163 |
| | | | | | J |  | M8 Bolt Cap | 8 | 1061164 |
| | | | | | K |  | M6 Lock Washer | 10 | 1051163 |
| | | | | | L |  | M8 Lock Washer | 8 | 1063162 |
| | | | | | M |  | M6 Allen Key | 1 | 1010162 |
| | | | | | N |  | M8 Allen Key | 1 | 1051162 |
| | | | | | O |  | Adjustable Footpad | 4 | 2SIF001 |

STEP 1 & 3: PILLAR ASSEMBLY

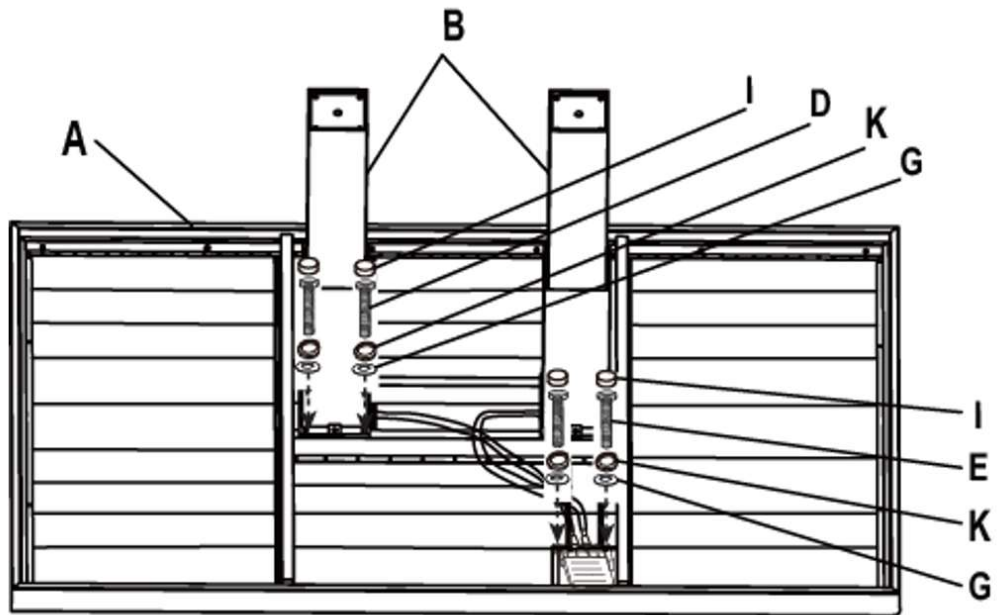

STEP 1: Attach leg pillar (B) to the table top (A), using the M6x25 bolt (D), lock washer (K) and washer (G).

STEP 2: Attach the handle to the Table top (A), using the M6x35 bolt (E), lock washer (K) and washer (G).

Tighten all the bolts and cover with the bolt cap (I)

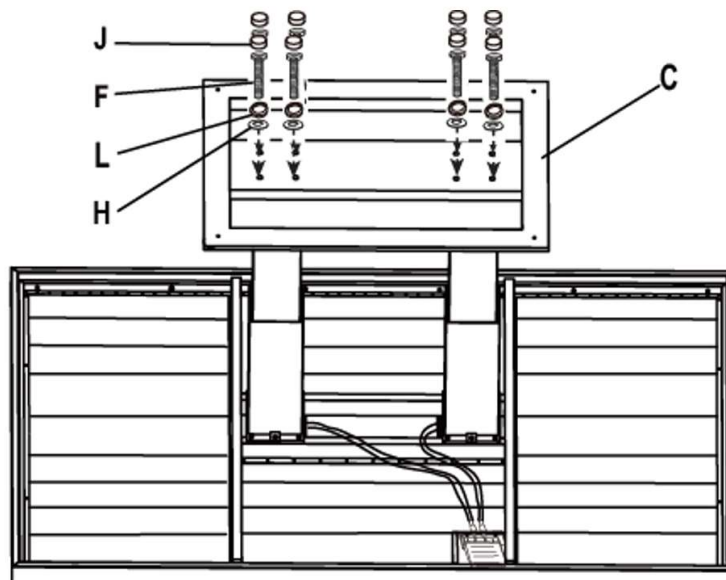

STEP 3: Attach base (C) to the pillar (B), using the M8x55 bolt (F), lock washer (L) and washer (H)

Tighten all the bolts and cover with the bolt cap (J)

Turn the table over, the table is now ready for use.

STEP 4: COMPLETE - RAISING AND LOWERING THE TABLE

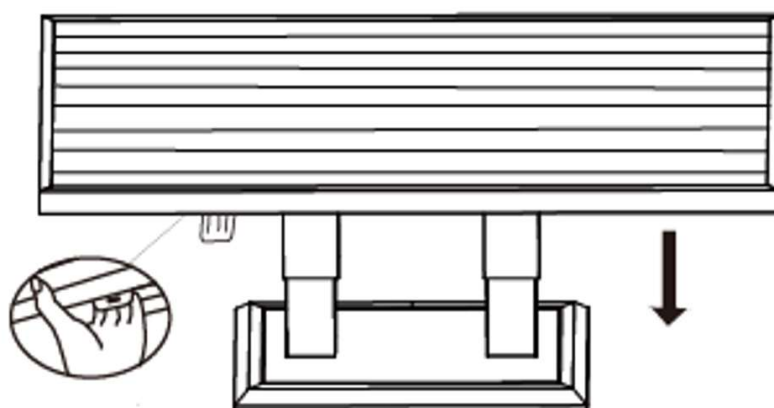
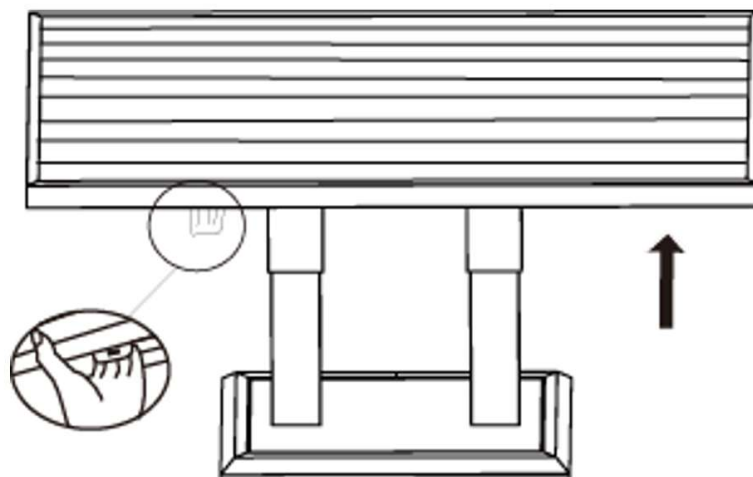
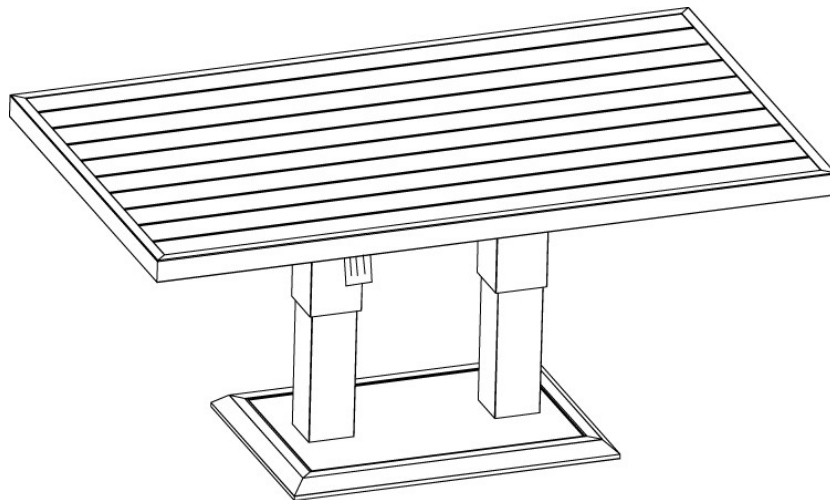

STEP 4: To raise the table gently squeeze the handle,
To lower the table, press gently on the centre of table top while squeezing
the handle.



Assembly Instructions

Sonas Square Side Table **(Product Code: 69104062)**

**PLEASE RETAIN THIS DOCUMENT ALONG WITH YOUR
PROOF OF PURCHASE FOR FUTURE REFERENCE**

Congratulations on your recent purchase of your beautiful Hartman furniture. We hope it brings you bountiful special moments with friends and family for many years to come. Please follow these simple steps to build your furniture. We also have a very useful video available online to assist with the assembly, please visit www.hartmanuk.com

TOP TIPS

- Please read these instructions carefully before assembly. For further assistance please view our assembly video online for an easy step by step demonstration.
- Aluminium is a soft metal and over tightening may strip the thread or break the part, please loosely assemble your furniture before tightening to secure.
- Please **do not** use power tools, please only use the tools provided in the bolt pack.
- Please allow 1 hour for assembly.
- This furniture can be assembled with 1 person; however, you may need someone to assist you when turning the furniture over into position.

STEP 1 & 2: LEGS ASSEMBLY

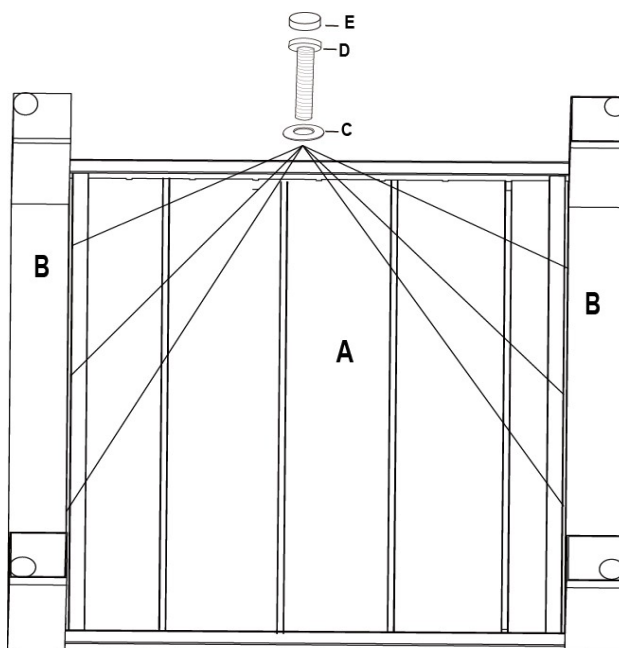

STEP 1: Attach leg (B) to the table top (A) using the M6x35 bolt (D) and washer (C)

STEP 2: TIGHTEN AND FINISHING

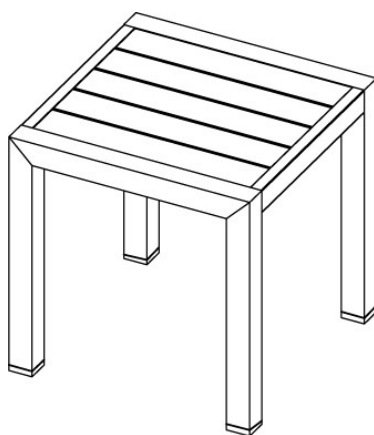

STEP 2: Finally tighten all the bolts and add the bolt caps (F) to the bolts.