

PLEASE KEEP ME WITH YOUR PROOF OF PURCHASE FOR FUTURE REFERENCE

ATTENTION:











1. Please read these instructions carefully before assembly
2. Aluminium is soft metal and over tightening may strip thread or break the part
3. **DO NOT** use power tools
4. Please allow 30 minutes for assembly.
5. Although assembly only requires 1 person it is advised that a second person be present to help turn the table over and into position when fully assembled

ASSEMBLY STEPS:

1. Turn the seating panel (A) upside down on a soft clean surface
2. **LOOSELY** attach Left leg frame (B) and right leg frame (C) to the seating panel (A) with bolts(G), bolts(H) and big flat washers(I) using Allen key(J)
3. **LOOSELY** attach assembled crossing bar (D) to assembled leg frames with bolts (G) and big flat washers (I) using Allen key (J) **DO NOT TIGHTEN THE BOLTS AT THIS STAGE**
4. **LOOSELY** attach assembled middle leg (E) to assembled leg frames with bolts (G) and big flat washers (I) using Allen key (J) **DO NOT TIGHTEN THE BOLTS AT THIS STAGE**
5. Turn sofa over and **LOOSELY** attach backrest (F) to seating panel and assembled leg frames with bolts (H) and big flat washers (I) using Allen key (J)
6. Tighten all bolts using Allen key (J) one by one being careful not to over tighten any as this will cause the thread to become damaged
7. Place all cushions on the sofa seat and place sofa in desired position.

For more information regarding maintenance of your furniture please visit

http://www.hartmanuk.co.uk/after_care_videos.html

Component's					Fixings				
Parts List	Parts Picture	Description	Q'ty	Part no	Parts list	Parts Picture	Description	Q'ty	Part no.
A		Seating panel	1	69472002A	F		Backrest	1	69472002E
					G		M6*20 bolts	8	1017162
B		Left arm with leg frame	1	69472002B	H		M6*35 bolts	10	1111162
C		Right arm with leg frame	1	69472002C	I		Big Flat washers	18	1061162
D		Crossing bar	1	69472002D	J		Allen Key	1	2002191
E		Middle leg	1	69472002E					

For replacement or lost spare parts please go to <http://faq.hartmanuk.co.uk/spares/>

Should you have any queries about your furniture your first point of contact should be the retailer from whom you purchased your product

PLEASE KEEP ME WITH YOUR PROOF OF PURCHASE FOR FUTURE REFERENCE



ASSEMBLY INSTRUCTIONS

Vienna 3 Seat Lounge Sofa & 2 x Lounge Chairs

(69472002)

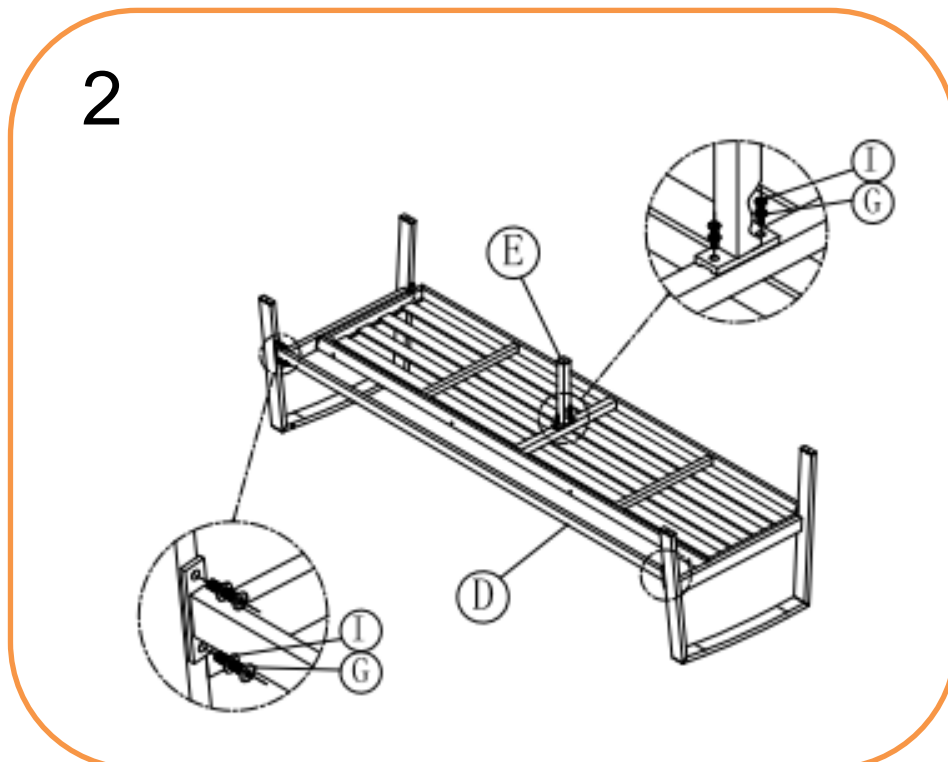
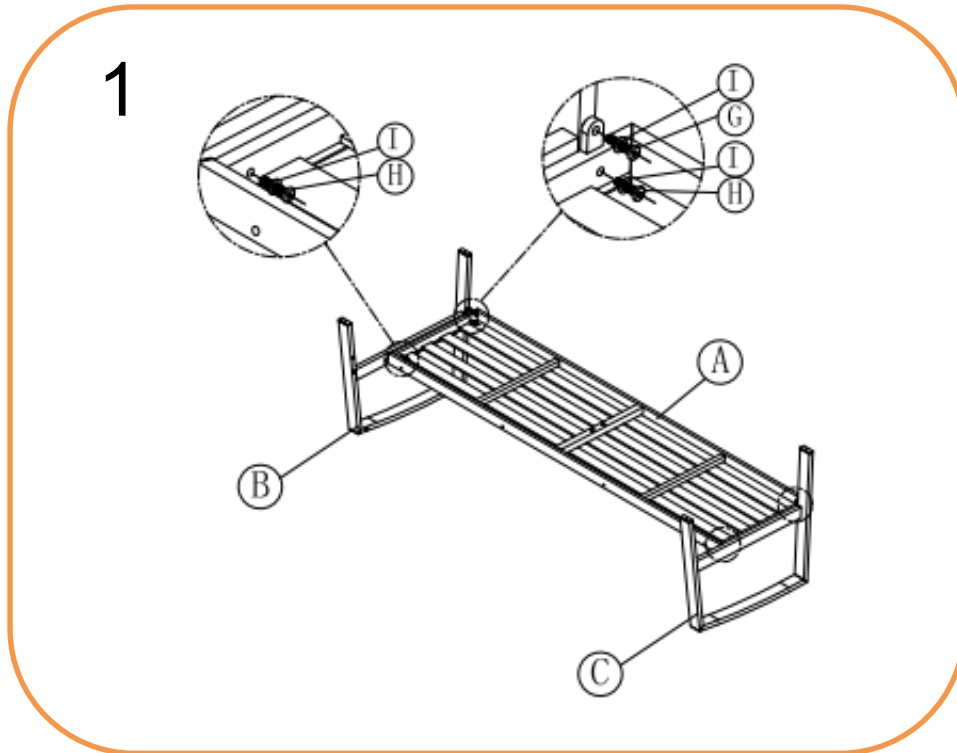

For replacement or lost spare parts please go to <http://faq.hartmanuk.co.uk/spares/>
Should you have any queries about your furniture your first point of contact should be the retailer from whom you purchased your product

PLEASE KEEP ME WITH YOUR PROOF OF PURCHASE FOR FUTURE REFERENCE



3

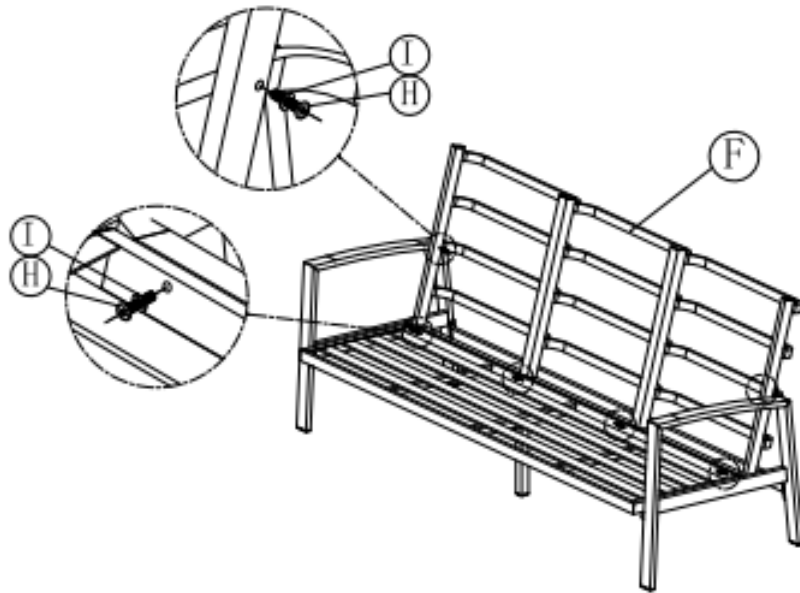

4

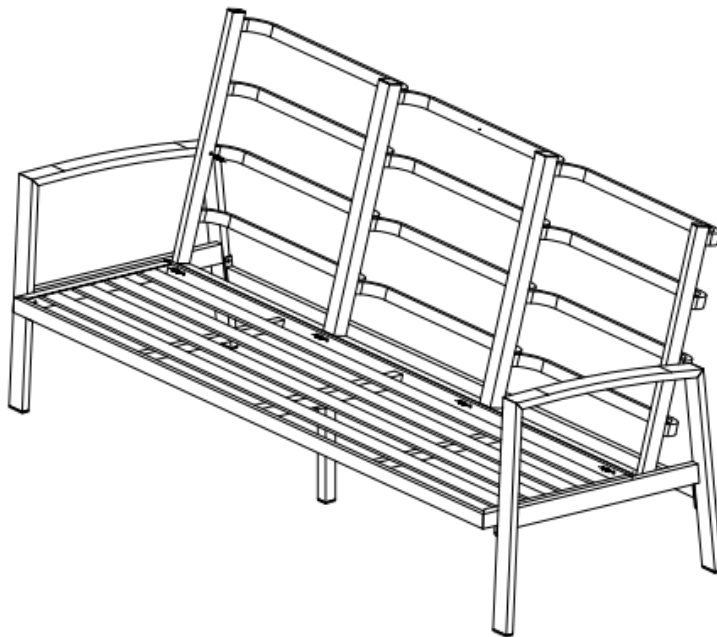

For replacement or lost spare parts please go to <http://faq.hartmanuk.co.uk/spares/>
Should you have any queries about your furniture your first point of contact should be the retailer from whom you purchased your product

PLEASE KEEP ME WITH YOUR PROOF OF PURCHASE FOR FUTURE REFERENCE

ATTENTION:









1. Please read these instructions carefully before assembly
2. Aluminium is soft metal and over tightening may strip thread or break the part
3. **DO NOT** use power tools
4. Please allow 30 minutes for assembly.
5. Although assembly only requires 1 person it is advised that a second person be present to help turn the table over and into position when fully assembled

ASSEMBLY STEPS:

1. Turn the seating panel (A) upside down on a soft clean surface
2. **LOOSELY** attach Left leg frame (B) and right leg frame (C) to the seating panel (A) with bolts(F), bolts(G) and big flat washers(H) using Allen key(I)
3. **LOOSELY** attach assembled crossing bar (D) to assembled leg frames with bolts (F) and big flat washers (H) using Allen key (I) **DO NOT TIGHTEN THE BOLTS AT THIS STAGE**
4. **Turn sofa over and LOOSELY** attach backrest (E) to seating panel and assembled leg frames with bolts (G) and big flat washers (H) using Allen key (I)
5. Tighten all bolts using Allen key (I) one by one being careful not to over tighten any as this will cause the thread to become damaged
6. Place all cushions on the sofa seat and place sofa in desired position.

For more information regarding maintenance of your furniture please visit

http://www.hartmanuk.co.uk/after_care_videos.html

A		Seating panel	1	69021149A	F		M6*20 bolts	6	1017162
					G		M6*35 bolts	8	1111162
B		Left arm with leg frame	1	69021149B	H		Big Flat washers	14	1061162
C		Right arm with leg frame	1	69021149C	I		Allen Key	1	2002191
D		Crossing bar	1	69021149D					
E		Backrest	1	69021149E					

For replacement or lost spare parts please go to <http://faq.hartmanuk.co.uk/spares/>

Should you have any queries about your furniture your first point of contact should be the retailer from whom you purchased your product

PLEASE KEEP ME WITH YOUR PROOF OF PURCHASE FOR FUTURE REFERENCE

1

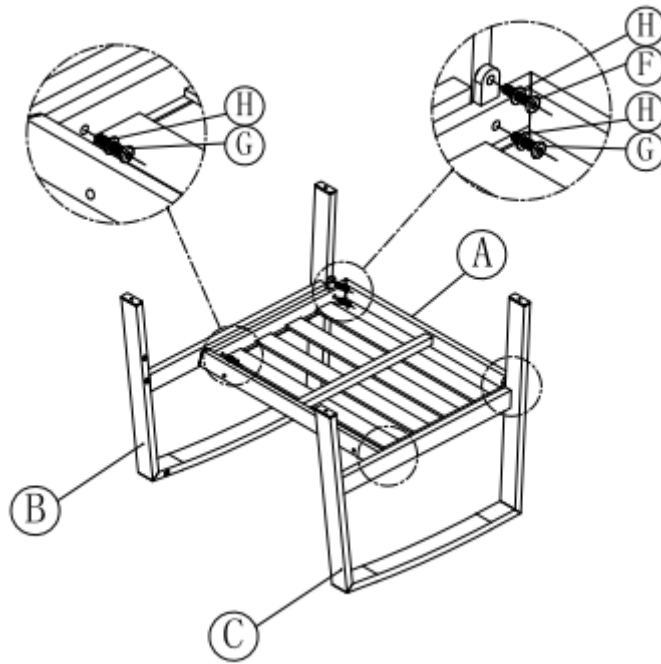

2

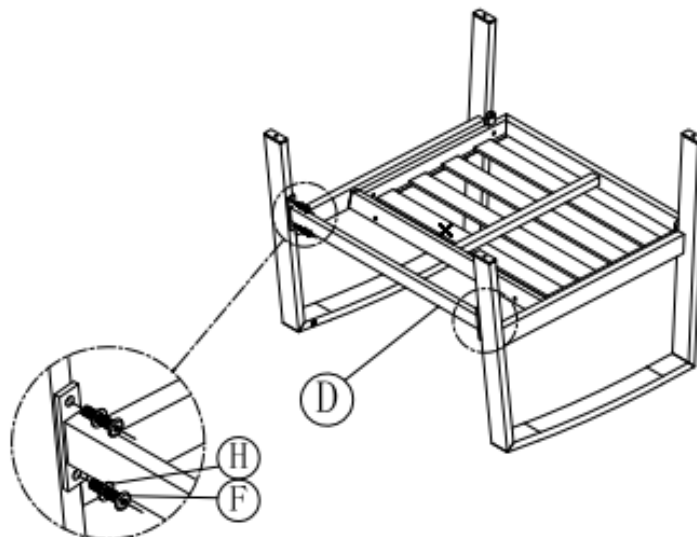

For replacement or lost spare parts please go to <http://faq.hartmanuk.co.uk/spares/>
Should you have any queries about your furniture your first point of contact should be the retailer from whom you purchased your product

PLEASE KEEP ME WITH YOUR PROOF OF PURCHASE FOR FUTURE REFERENCE

3

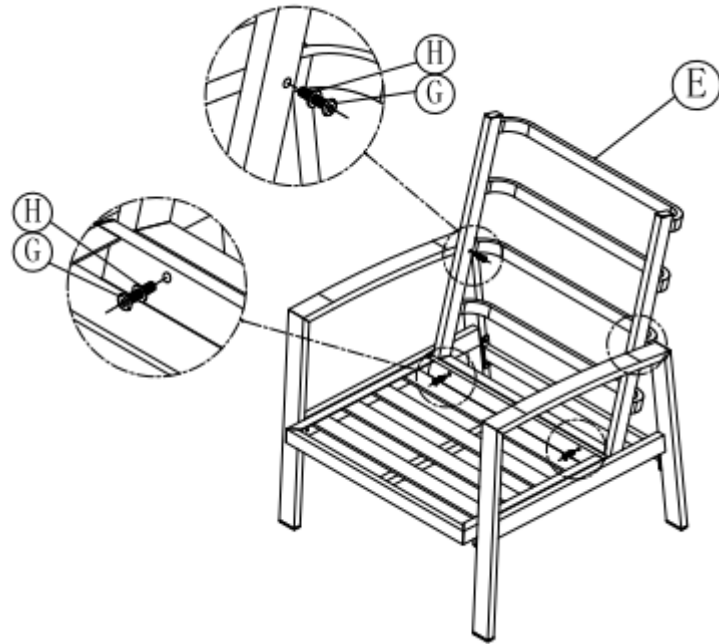

4

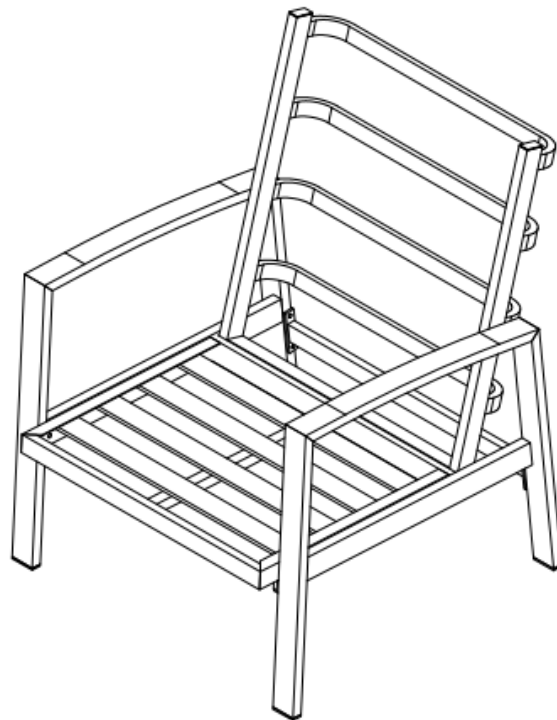

For replacement or lost spare parts please go to <http://faq.hartmanuk.co.uk/spares/>
Should you have any queries about your furniture your first point of contact should be the retailer from whom you purchased your product